

Better Water LLC

MediPac
(Tank Feed)

Operator Manual



rev. Jun 2016

Better Water LLC. All rights reserved.

The content of this manual is the intellectual property of Better Water LLC. It is furnished for the express use by Better Water LLC, their customers and dealers, for informational use only for operation, service, and internal training. No part of this manual may be reproduced for distribution, sale, or any intent other than previously described without the written permission of Better Water LLC. This manual is subject to change without notice. Better Water LLC assumes no responsibility or liability for any error or inaccuracies that may appear in this documentation.

Adobe and Acrobat are registered trademarks of Adobe Systems, Inc.

TABLE OF CONTENTS

Our Company	01
- Contact Us	01
- Technical Phone Support	01
- Technical Support Info Online	01
- Specific Contacts	02
Introduction	02
Warnings	03
Cautions	03
General Requirements and Specifications	04
Models	05
Important Information for Support	05
Product Description	06
Detailed View of the MediPac	
- Pre-Treatment Side	07
- RO End	07
- Post-Treatment End	08
System Components:	
- MediPac Control Box	09
- Pre-Treatment; Pressure Gauges	09
- Pre-Treatment; Thermometer	10
- Pre-Treatment; Blending Valve	10
- Pre-Treatment; City Booster Pump	11
- Pre-Treatment; Automatic Control Valves	11
- Pre-Treatment; Interlock Wiring System	12
- Pre-Treatment; Water Softener	13
- Pre-Treatment; Brine Tank	14
- Pre-Treatment; Carbon Media Filtration	15
- Pre-Treatment; Ultra-Violet Irradiation (Pre-RO)	16
- Pre-Treatment; Particulate Filtration Cartridge (10" Big Blue, 5 micron filter)	17
- 1232 RO	18
- Post-Treatment; Repress Pump	19
- Post-Treatment; Ultra-Violet Irradiation (Post-RO)	20
- Post-Treatment; Pyrogen Cartridge (20", .03 micron ultra-filter)	21
- Post-Treatment; Particulate Filtration (10" Big Blue, 5 micron filter)	22
- Divert-to-Drain, Wall-Mounted	23
- Storage Tank and Level Control System	24
- Remote Alarm Box	25
- Disinfect Tank	25
Operation	
- General Operation	26
- Valves Legend	27
- Daily Start-Up	30
- Monitoring Procedures	31
- Daily Shutdown	31

Cleaning & Disinfecting

- General Cleaning and Disinfecting Overview 32
- Cleaning and Disinfecting Agents 33
- Disinfecting and Cleaning Procedure 34
- Disinfect/Clean the RO 34
- Disinfect the Post-Treatment, Storage Tank, and Distribution Loop 37
- Sanitizing the Sanitary Sample Ports 39

Water Leak Detector 40

Switching to Temporary DI 41

System Maintenance

- General 44
- Long Term Storage or Non-Use 45
- Adjusting the Blend Valve Temperature Setting 45
- Priming the City Booster Pump and Repress Pump 47
- Change Particulate Filter Cartridges and Pyrogen Filter 48
- Automatic Control Valves; Set Time of Day 49
- Automatic Control Valves; Set on Which Days to Regenerate/Backwash 49
- Automatic Control Valves; Initiate a Manual Regenerate/Backwash 49
- Automatic Control Valves; Changing Regenerate/Backwash Program Cycles 50
- Automatic Control Valves; Replacing Seals and Spacers 51

Service Help

- MediPac, Post-Treatment End 53
- MediPac; 1232 RO End 54
- MediPac; Front-Side 55
- MediPac Control Box (front view) 56
- MediPac Control Box (inside lid view) 57
- MediPac Control Box (inside view) 58

Related Consumable and Replacement Items 59

Related Disinfectants & Cleaners 61

Related Consumable Media 62

Limited Warranty Terms and Conditions 63

Appendix A, Sample Quality Assurance Checklist 65

Appendix B, Bleach Use in the Post-Treatment Components (Tank-Feed Systems Only).... 68

Appendix C, Calculations & Conversions

- Conversion Formulas 69
- Calculation for Area of Pipe Volume 69
- 3 Feet per Second Flow Velocity Rates 70

Our Company

Better Water LLC is a leading integrated manufacturer of water treatment equipment and components for the industrial, commercial and institutional markets.



Located in Smyrna, Tennessee, Better Water LLC continues its history of manufacturing and distribution of equipment specifically designed for the renal dialysis market.

Founded in 1971, Better Water LLC has built a reputation for solving our customers' toughest problems with high quality products and unmatched service.

Contact Us

Better Water LLC
698 Swan Dr
Smyrna, TN 37167

Phone (615) 355-6063
Fax (615) 355-6065

Technical Support:
Phone (615) 355-6063, press "1"
Email support@betterwater.com

Customer Service:
Phone (615) 355-6063, press "3"
Email customerservice@betterwater.com

Technical Phone Support

Support is available regarding all Better Water LLC systems, **24 hours a day, 7 days a week.**

- Normal business hours are [Monday through Friday](#) from **8:00 am until 3:30 pm, Central Standard Time** (*excluding holidays*)

Call (615) 355-6063, press "1" for Technical Support

Emergency assistance is available after normal business hours (*including holidays*) by calling **(615) 708-8627**.

Technical Support Info Online

Our website, www.betterwater.com, which is updated frequently, contains a wealth of technical support information on the **SUPPORT** tab and includes:

- Operator and Service Manuals
- Consumables and Accessories Lists
- Technical Service Bulletins

For your convenience there are also online forms for placing **Orders** and requesting **Returned Goods Authorization**. These are Adobe forms that can be downloaded and either faxed or emailed to us.



Specific Contacts

Technical Support	Phone (615) 355-6063, option "1"
	Email support@betterwater.com
To Place an Order (purchase orders)	Fax (615) 355-6065
	Email orders@betterwater.com
	Phone (615) 355-6063
Customer Service (returns)	Phone (615) 355-6063, option "2"
	Fax (615) 355-6065
	Email customerservice@betterwater.com

Website www.betterwater.com

Helpful information and forms that can be found on our website:

- Operator & Service Manuals
- Technical Service Bulletins
- Consumables and Replacement Parts List
- Brochures
- Order Form
- Return Goods Authorization Request Form

Introduction

The Better Water LLC MediPac System is manufactured to the utmost quality. With proper operation, maintenance, and care, this device should give you years of reliable service.

Before starting you should first read and have a thorough understanding of this entire Operator Manual. It describes in detail the steps and procedures for safe usage of this system.

This device was designed and built with consideration for the information that has been provided to use on the current product water requirements at your site of operation.

This device was designed and built as a complete water treatment system to produce high-quality water for hemodialysis, and is not intended for any other application.

Once the this device has been delivered, it is the responsibility of the Medical Director to ensure that it is used, monitored, and maintained in such a manner so as to satisfy all applicable standards. Guidelines and other related information are available from:

- Food and Drug Administration (FDA)
- National Association of Nephrology Technicians/Technologists (NANT)
- Association for the Advancement of Medical Instrumentation (AAMI)



NOTE concerning pictures in this manual:

Pictures of devices and components may vary slightly due to product changes, and therefore should be for general reference only. Information concerning their use, functionality, or replacement will not differ unless noted.

WARNINGS



1. It is unsafe to operate or service this device without first reading and understanding the **entire** Operator's Manual. Keep this manual and other associated documentation for future reference.
2. Misuse, improper operation, and/or improper monitoring of this system could result in serious injury, death, or other serious reactions to patients undergoing hemodialysis treatment.
3. Misuse, improper use or handling of disinfectants and chemical cleaning solutions could result in serious injury or even death. You must comply with the information contained in the Material Safety Data Sheet (MSDS) for the chemical being used.
4. To avoid electrical shock hazard, do not operate this device when the covers or panels are removed.
5.  **ELECTROMAGNETIC INTERFERENCE: This device can create and radiate radio frequency energy and may cause harmful interference if not installed according to the manufacturer's instructions.**

CAUTIONS



1. When used as a medical device, federal law restricts this device to sale by or on the authority of a physician. Per CFR 801.109 (b)(1).
2. Improper operation of this device could result in a low or no-flow alarm on the dialysis machines.
3. Misuse or improper operation of this device will void any warranty.
4. Where water is mentioned, unless otherwise noted, it must be AAMI standard quality water.
5. Plumbing connections must adhere to local statutes and any facility codes.
6. Do not remove any Caution, Warning or any other descriptive labels from the device.
7. Do not operate this device in an explosive environment or in the presence of flammable materials.
8. Do not use this device to store, mix or transfer flammable liquids. Movement or vibrations during shipment may cause connections to loosen.
9. Do not operate this unit in an environment where temperatures may be below 50° F or above 90° F.
10. This device should not be used for purposes outside the device's stated applications, specifications or limitations.

GENERAL REQUIREMENTS & SPECIFICATIONS

SPACE:

- The system should be level and located as close as possible to the point of use.
- Minimum space required Length 92" x Width 38" x Height 82".
- Additional space will be required for the water softener's brine tank, determined by the size of the tank.
- Additional space will be required for the storage tank if a Tank-Feed system, determined by the size of the tank.
- The floor must be capable of supporting up to 2500 lbs.
- Space considerations should include adequate operator access.

WATER SUPPLY CONNECTION:

- Requires a 1" female NPT threaded water connections, both hot and cold, with an adjacent shut-off valve.

FEED WATER SUPPLY REQUIREMENTS:

- The importance of monitoring and controlling the municipal tap water cannot be underestimated. The pre-treatment feed water must meet the following parameters:
 - Pressure: 30 psi (*minimum*) to 50 psi (*maximum*); 40 psi (***optimum***)
 - The minimum pressure must be maintained with water flowing at the maximum required flow-rate. This is dynamic pressure; not static pressure.
 - Flow Rate: 4 gallons per minute
 - Temperature: 50° to 90° F

DRAIN REQUIREMENT:

- Requires a sanitary drain capable of discharging 15 gpm (gallons per minute) or better.

ELECTRICAL CONNECTION:

- Two electrical outlets, 115 vac, single phase, with 20 amp breakers

MODELS

There is only one model of the tank-feed MediPac based around the 1232 RO.

Model	Specifications
EQMEDIPAC-2880-TF-10	Tank Feed, 2880 gpd



IMPORTANT INFORMATION FOR SUPPORT

Adhered to the side of each MediPac’s RO Control Box is a label containing important information relating to the specific unit, and details both the **Model** and **Serial Number**. Both of these pieces of information are very important in obtaining support, determining warranty, and properly servicing this unit. Please have this information available if you contact Technical Support.

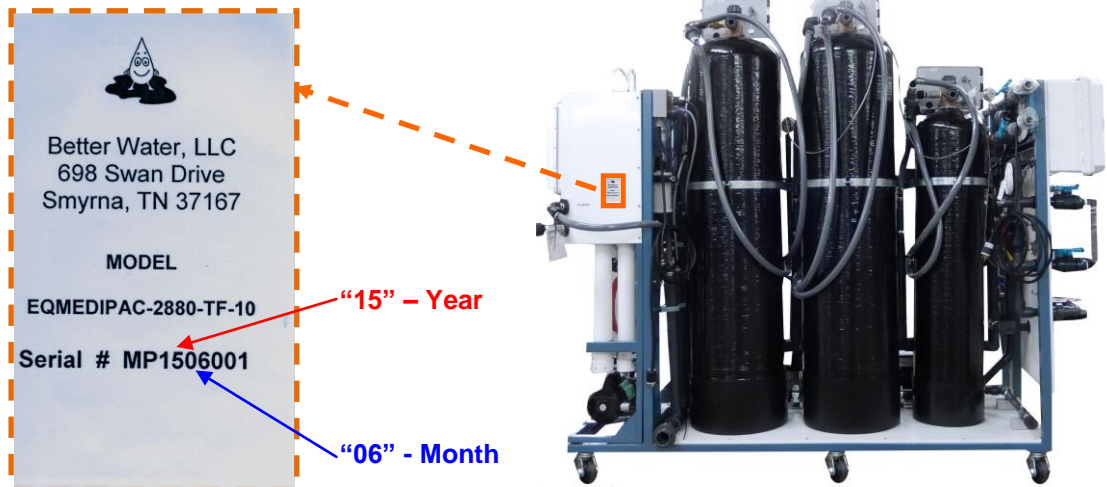

The first four numbers in the serial number denote the year and month the device was manufactured. *In the example above the unit, was produced in 2015, in the month of June.*

PRODUCT DESCRIPTION

The MediPac is designed to be a complete water system on a wheeled frame, which includes Pre-Treatment components, a 1232 RO, and Post-Treatment components. All three of these elements reside on a frame with the exception of the storage tank and brine tank. It designed to support six to eight stations.

The **Frame** is constructed of welded steel with a durable powder-coat paint finish to reduce rust and corrosion. The frame is mounted on sturdy casters for ease in moving should the need arise.

The **MediPac Control Box** is located on the left side (*post-treatment end*) of the rack, and both controls and provides power to many of the MediPac components. It also contains the components for a water leak detection system which will automatically close the main water shutoff valve in the event a water leak is detected.

The **Pre-Treatment** portion of this unit is comprised of the following components:

- A **Blend Valve** to maintain the proper water temperature.
- A **City Booster Pump** to maintain adequate pressure for the system to operate.
- **Carbon Filter Tanks** (*worker and polisher*) to remove chlorine and chloramines.
- A **Water Softener** to reduce water hardness by removing heavy metals such as calcium and magnesium from the water. Works in conjunction with a Brine Tank containing salt.
- An **Ultra-Violet Light** to reduce bacteria.
- A **Sediment Filter** for particulate and sediment filtration.
- There are also a **Temperature Gauge, Pressure Gauges** and **Sample Ports** for monitoring the system's operation.

The **Reverse Osmosis** unit is the **1232 RO**, which resides on right side of the MediPac frame. It consists of four membranes, and produces 2 gallons per minute RO water for the system.

The **Post-Treatment** portion of this unit is comprised of the following components:

- A **Ultra-Violet Light** to reduce bacteria.
- A **20" .03 Micron Filter** for bacteria and pyrogen filtration.
- **DI Connection** points for use with DI Tanks.
- A **10" Big Blue 5 Micron Filter** for Post-DI filtration.
- A **Repressurization Pump** to circulate water through the distribution loop.
- A Storage tank located near the unit is equipped with level controls to operate the RO.
- There are also a **Flow-Meter, Pressure Gauges**, and **Sample Ports** for monitoring the system's operation.



DETAILED VIEW of a MediPac, Front Side

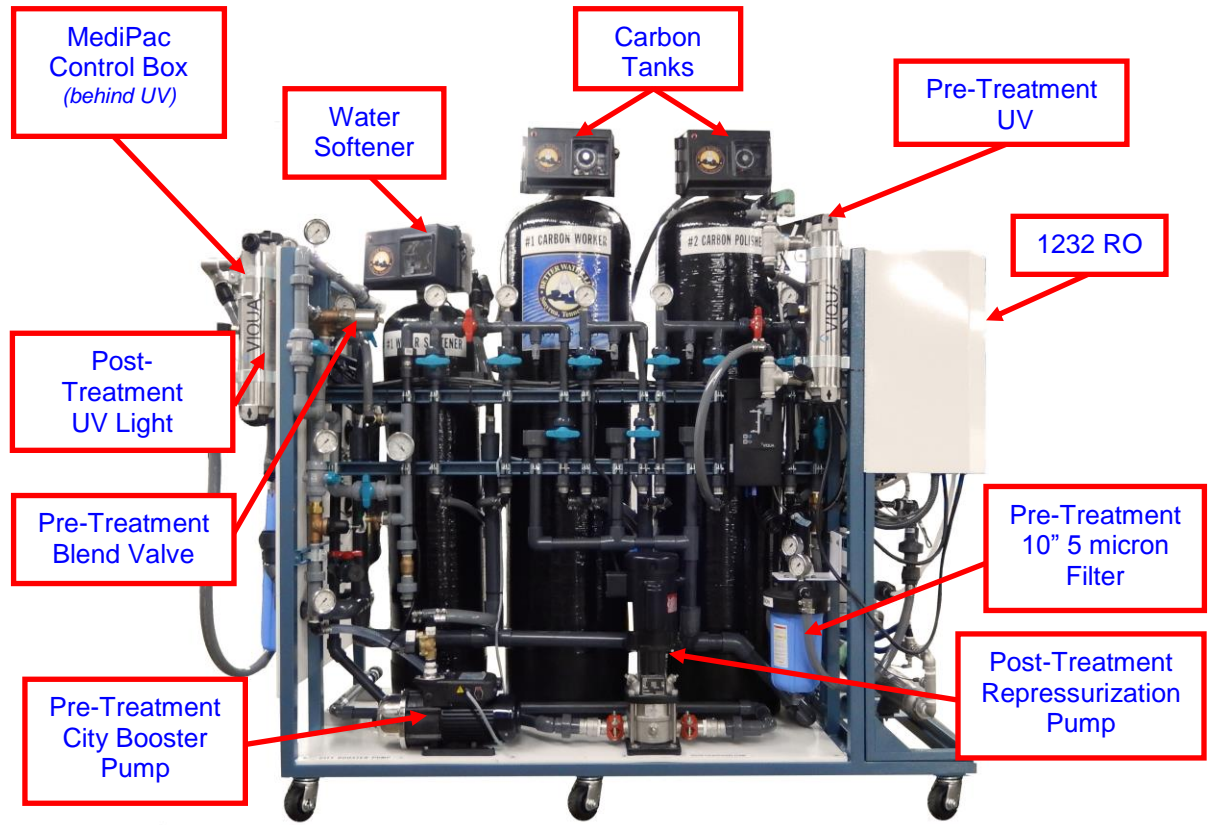

DETAILED VIEW of a MediPac, RO End

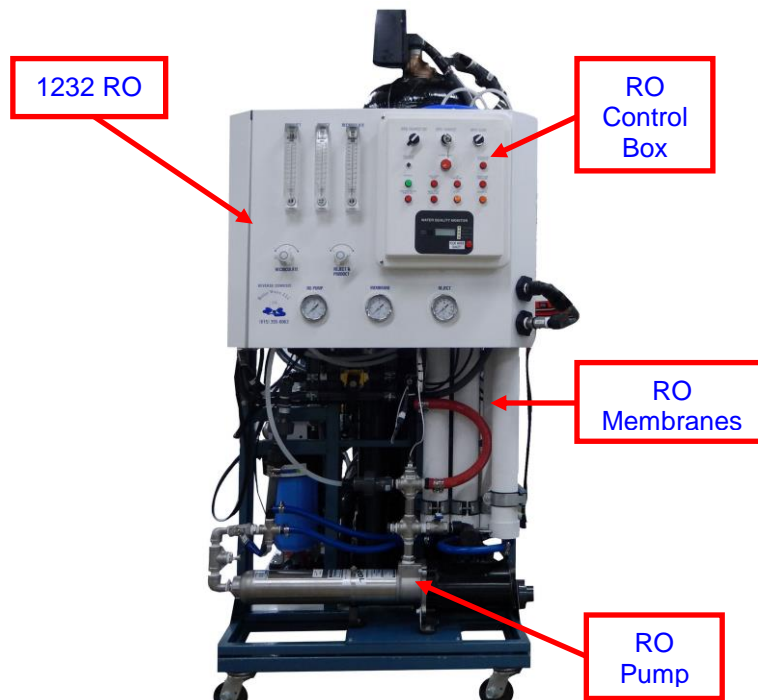

DETAILED VIEW of a MediPac, Post-Treatment End

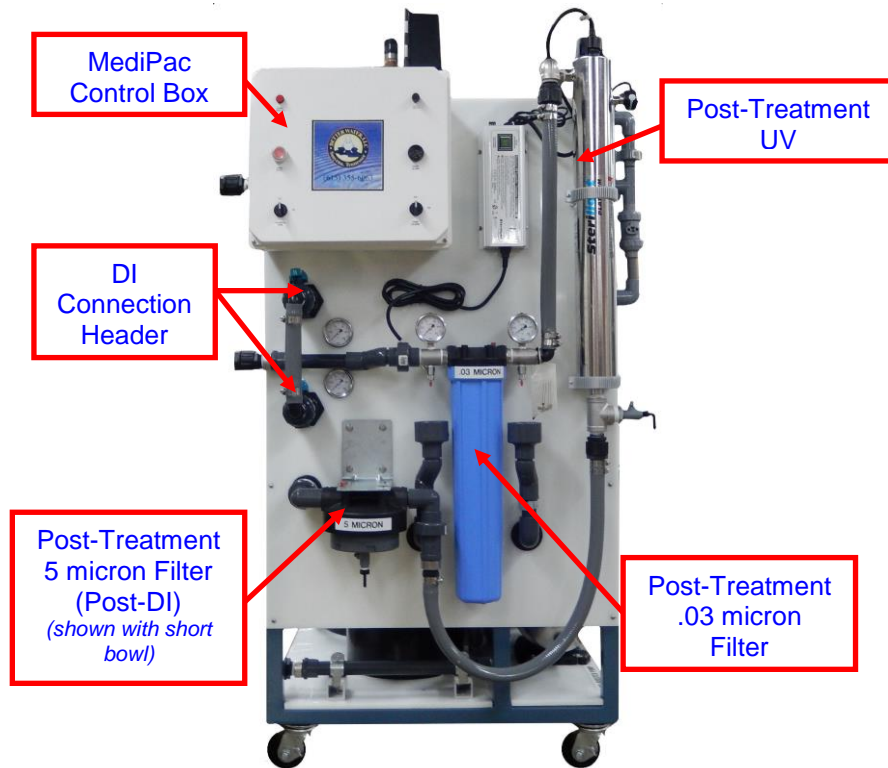

SYSTEM COMPONENTS: MediPac Control Box

DESCRIPTION:

The control box is a water-tight, chemical resistant box, containing electronic components needed to control and provide power to many of the MediPac's components.

The MediPac Control Box does the following:

- Facilitates the Level Controls from the RO and Storage Tank
- Controls the Water Leak Detector and Alarm
- Controls the Repress Pump
- Controls the Pre-Treatment UV and its UV Dump Valve
- Provides power to the Post-Treatment UV
- Contains components of the water leak detector and will alarm and close the main-water shutoff valve if a water leak is detected.



Specific operating details are discussed later in this manual.

SYSTEM COMPONENTS: PRE-TREATMENT; Pressure Gauges

DESCRIPTION:

The monitoring of components in any water treatment system depends highly on monitoring the pressures before and after the component. Most components in the system will have less than 15 psi normal differential pressure. When this differential pressure rises toward or exceeds 15 psi, the component will require attention to determine the problem or cause.



Differential Pressure or **Delta Pressure** (represented by the symbol ΔP) is equal to the Inlet Pressure minus the Outlet Pressure when the RO is running.

$\Delta P = \text{Inlet Pressure} - \text{Outlet Pressure}$. Example: If the #1 carbon filter is showing an inlet pressure of 60psi and an outlet pressure of 55 psi, the Δ pressure is 5 psi. Under most circumstances, the normal ΔP of most components will be less than 15 psi.

Most components in a Better Water LLC water system are supplied with gauges that will show the pressure before and after the specific component. Gauges used before the RO will be made of brass and stainless steel. Gauges used in and after the RO will be made of stainless steel only. All gauges in the system will be 0-100 psi, dry (*not glycerin filled*), with a 1.5% accuracy.

SYSTEM COMPONENTS: PRE-TREATMENT; Thermometer

DESCRIPTION:

Maximum water production of the RO depends greatly on the temperature of the feed water. Water that is too cold will require more pressure from the RO pump to force it through the membranes, which will put undue stress on them, causing the membrane pressure to rise. Water that is too hot can cause damage to the membranes. If the water gets too hot, the RO will shut down in a high feed temp alarm.



77° F is the temperature for optimum performance of the Better Water LLC. RO. The pre-treatment system has a stainless steel, in-line temperature gauge located just after the blend valve. This temperature gauge will monitor the blend valve to assure adequate water temperature of the water being supplied to the RO. The blend valve will normally be set at approximately 72-75°F.

SYSTEM COMPONENTS: PRE-TREATMENT; Blending Valve

DESCRIPTION:

The blending valve is an automatic, mechanical device that instantly compensates for supply line temperature and pressure changes to maintain the pre-selected temperature of the feed-water. The manufacturer states that this device complies with the requirements of Federal specifications WW-P-541/7B and all other known standards, codes, and specifications.



MONITORING REQUIREMENTS:

Daily: Verify the selected temperature range while the RO is running.

MAINTENANCE:

* See System Maintenance section for how to adjust the blend valve, thus affecting water temperature.

NOTE: The manufacturer states that this device, "Fails safely on hot or cold supply failure of thermal motor failure (when so specified) to shut down flow." When feed water flow ceases, the RO unit will shut down, producing a low feed pressure audible and visual alarm on the RO and on any remote alarm locations.

SYSTEM COMPONENTS: PRE-TREATMENT; City Booster Pump

DESCRIPTION:

The city booster pump is a stainless steel, multi-stage, centrifugal pump designed for continuous duty service. The pump is powered by a 1 HP, single phase, 115 vac motor. The pump starts automatically when there is a demand for water. This pump is designed for boosting water pressure for circulation service.

Pump models may vary between devices.

MONITORING REQUIREMENTS:

Daily: Monitored to ensure desired pressure is maintained.

MAINTENANCE:

* See *System Maintenance* section for priming instructions.



part#
EQPUGR01905
City Boost Pump
Grundfos MQ Series

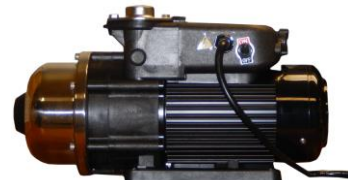

part#
EQPUWA00251
City Boost Pump
Walrus TQ-800

SYSTEM COMPONENTS: PRE-TREATMENT; Automatic Control Valves

DESCRIPTION: All automatic backwashing filters and softeners are equipped with automatic control valves, which control the backwashing/regeneration times, cycles, and frequencies for the specific filter it operates. These feature a 7 day calendar time clock and has an interlock feature to prevent the RO from running while the filter is in backwash or regeneration. (See *Interlock Wiring System Section*)

MONITORING REQUIREMENTS:

Daily: Verify the controller day, and time of day is properly set.

MAINTENANCE:

- The seals and spacers in the valve should be changed every 3 to 5 years. This may have to be done sooner if there is a malfunction of the device.

* See *System Maintenance* section.



SYSTEM COMPONENTS: PRE-TREATMENT; Interlock Wiring System

DESCRIPTION:

The interlock wiring system is a safety feature, incorporated into all Better Water LLC water systems, is a low voltage (24 vac) lockout system designed to shut down the RO machine, if running, or prevent the RO from running, when any filter or softener goes into backwash or regeneration.

A 24 volt signal originates at the RO and is sent to each selected piece of pre-treatment equipment in series, and the last piece of equipment is equipped with a "jumper" to return the signal to the RO. When a filter or softener goes into backwash or regeneration mode, the signal is redirected to a red light on the specific control valve, which illuminates to indicate the backwash or regeneration mode of that piece of equipment. It also starts the city booster pump, and opens the blend valve bypass. With this signal not being returned to the RO, the RO will not run or will stop if running when the signal is broken. The interlock wiring system utilizes quick-connect fittings on all connections.

SYSTEM COMPONENTS: PRE-TREATMENT; Water Softener

DESCRIPTION: Water softening consists of a single water softener to meet system flow demands, reduction ratios, and user criteria. The water softener in this system is commercial/industrial grade, automatic, and custom sized to meet the demand.

The water softener in the system has a 7 day calendar time clock to control regeneration. The controller can be set to regenerate at pre-set times on specific days, giving the user maximum flexibility. The controller has an interlock feature to prevent the RO from running during the regeneration cycle. When regenerating a red light is illuminated as an indicator of this cycle and the RO will not run due to the interlock.

The resin is a premium grade, strong acid cation for high flow rate condensate demineralizing made from food-grade materials that meet FDA CFR 173.25 specifications. The water softener is regenerated with salt brine that is made from quality, premium grade salt pellets specified for water softening and/or conditioning. **Do not use rock salt**, as this form of salt carries impurities and will tend to have adverse effects on your water pre-treatment system. For information on about brine tanks, see the previous section titled "System Components: Brine Tanks".



MONITORING REQUIREMENTS:

Daily: This device requires daily monitoring to insure the controller clock is properly set

Daily: Check pre and post-filter pressure, and ΔP (*pressure drop*) across it while the RO is running

Daily: Check the salt level in the brine tank is greater than 50%

Daily: The hardness, measured post softener, should be tested daily while the softener is under peak demand, usually late in the afternoon.

MAINTENANCE:

- The salt level in the brine tank should be filled periodically so it doesn't fall below 50%.

- Better Water LLC recommends that tank media be changed every three years unless...

... otherwise specified by the medical director and/or company policies,

... or the hardness breakthrough is greater than 2 grains per gallon after two verified regeneration cycles.

SYSTEM COMPONENTS: PRE-TREATMENT; Brine Tank

DESCRIPTION:

The water softener includes a brine tank that holds the salt which produces the brine solution for the regeneration of the water conditioning resin. The brine tanks supplied with all Better Water LLC water softeners are made of a non-corrosive, plastic with a plastic grid plate in the bottom to reduce or eliminate “bridging” of the salt (*see note below*). On the inside of the tank is a brine well which houses the brine valve. This brine valve is connected with a 3/8” or larger brine line to a single or duplex softener. Only one brine tank is required for a duplex system. This tube serves to draw the brine solution out of the brine tank during the “brine draw” cycle, and also to refill the brine tank during the “brine refill” cycle of the control valve.



Better Water, LLC utilizes three safety measures with the brine valve; First, located on the bottom of the brine valve is an air check valve. This is a device incorporated into the brine valve to stop the flow through the brine tube in case the brine level drops to an insufficient level. This will prevent the control valve from drawing air into the system. Second, the brine valve is equipped with a float valve on the top, to prevent the brine tank from overflowing, in the event of a control valve malfunction, event of a power outage during the refill cycle. Thirdly, an overflow line is installed, in the rare case of overflow; the excess will be routed to a suitable drain.

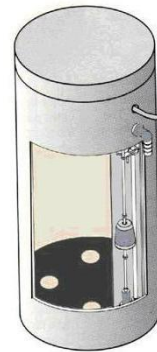

Cutaway view of brine tank

The brine tank should only be filled with quality, premium grade salt pellets specified for water softening and/or conditioning. **Do not use rock salt**, as this form of salt carries impurities and will tend to have adverse effects on your water pre-treatment system.

NOTE: Bridging occurs in brine tanks when the salt sticks together to form one large solid mass of pellets, or by the salt caking in a dry-salt brine tank which causes failure of the liquid or brine beneath the dry salt to become saturated. The result of bridging is insufficient salt in the regeneration solution to properly regenerate the cation resin.

Brine tanks are sized according to the size of the water softener, organic scavenger, and dealkalizer vessels. Better Water LLC, primarily uses 2 sizes of brine tanks. 16” diameter and smaller devices will be supplied with an 18” diameter brine tank. 20” and larger devices will be supplied with a 24” brine tank. 30” and larger devices, although seldom used, can be supplied with even larger brine tanks. On occasion, a customer will request a smaller brine tank, due to space restrictions. Although adequate with some procedural modifications, this is not recommended. A smaller brine tank will require salt filling more often.

MONITORING REQUIREMENTS:

Daily: Daily monitoring of the salt level in the brine tank is required, refilling as necessary.

MAINTENANCE:

- The salt level in the brine tank should be filled periodically so it doesn’t fall below 50%. The salt level should be maintained above the water level in the tank. It is recommended that the salt level to rise and fall over time, and not just “top off” on a daily basis, which will allow a good “turn-over” of the salt in the tank.

NOTE: It takes a minimum of 3 to 4 hours to fully saturate the water in the brine tank after refilling for maximum results.

Brine tanks should be emptied and cleaned annually, or more often if necessary.

SYSTEM COMPONENTS: PRE-TREATMENT; Carbon Media Filtration

DESCRIPTION:

Carbon filtration is based upon a naturally occurring phenomenon called adsorption, in which molecules of a liquid or gas are trapped by either the external or internal surface of a solid. Activated carbon has a very high internal surface area and thus is an ideal material for adsorption. Raw water quality can be improved with the removal of trace components.

Carbon filters are backwashed periodically (*every other day*) to expose new adsorption sites in the media. After backwash, a down-flow rinse prepares the media for service.

Carbon filtration consist of at least 2 properly sized pressure vessels (*tanks*) which are filled with predetermined volumes of carbon. In most systems, two properly sized, backwashable carbon filters are connected in series with tank #1 adsorbing the entire load and tank #2 performing a polishing task while providing a back-up capability.

Each carbon filter in the system has a 7 day calendar time clock to control backwashing. The controller can be set to backwash at pre-set times on specific days, giving the user maximum flexibility. The controller has an interlock feature to prevent the RO from running during the backwash cycle. When backwashing a red light is illuminated as an indicator of this cycle and the RO will not run due to the interlock.

The carbon selected is of the highest quality available and meets our demanding specifications for chlorine/chloramine removal. The carbon is granular activated, acid washed, and designed for the purification of aqueous liquids which may be sensitive to acid soluble constituents such as iron.

MONITORING REQUIREMENTS:

Daily: Daily monitoring should be done to insure that chlorine/chloramine free water is available prior to each hemodialysis treatment shift. This will require testing for chlorine/ chloramines before the first treatment of the day and prior to each treatment shift throughout the day.

Daily: This device requires daily monitoring to insure the controller clock is properly set

Daily: Check pre and post-carbon tanks (*both worker and polisher*), and ΔP (*pressure drop*) across them while the RO is running

MAINTENANCE:

- Better Water LLC recommends that tank media be changed every three years unless...
... otherwise specified by the medical director and/or company polices,
... or the chlorine/chloramines breakthrough is greater than 0.1 parts per million after two verified backwash cycles.



SYSTEM COMPONENTS: PRE-TREATMENT; Ultra-Violet Irradiation (Pre-RO)

DESCRIPTION:

The ultraviolet irradiation water disinfection unit consists of a UV lamp housed inside a fused quartz sleeve which seals the lamp from direct water contact. The sleeve, in turn, is housed in a stainless steel treatment chamber. The UV rays pass through the quartz sleeve and into the surrounding water. These UV rays alter the DNA of many common waterborne bacteria and sterilize (*prevent reproduction*) them. The low-pressure germicidal UV lamp produces a slightly shorter UV ray in concentrated form. 90% of the energy produced by this lamp has a wavelength of 254 nanometers, which will reduce many water-borne microorganisms.

MONITORING REQUIREMENTS:

Daily: This component must be monitored on a daily basis to insure the UV light is operating and the bulb is on.

MAINTENANCE:

- The UV bulb should be replaced every 12 months.
- Clean the quartz sleeve every 6 months.
- Change the quartz sleeve as needed.

Two models of UV lights have been used on the Medipac systems, which are detailed below.



part#
EQUVOO00896
UV SPV-410



part#
EQUVOO01907
UV Pro-Max 10



part#
SUUVOO02024
UV Bulb, SPV-410



part#
SUUVOO02023
UV Bulb, Pro-Max 10



part#
SUUVOO02025
UV Quartz Sleeve, SPV-410



part#
SUUVOO02022
UV Quartz Sleeve, Pro-Max 10

SYSTEM COMPONENTS: PRE-TREATMENT; Particulate Filtration Cartridge (10" Big Blue, 5 micron filter)

DESCRIPTION:

A basic particulate filtration consisting of a 10" housing fitted with a cartridge type filter element. These are specified to trap particulate matter of 5 microns or larger at a specified flow rate. There is a pre-filter and a post-filter gauge to measure pressure drop that indicates filter clogging. The filter housing is threaded for easy cleaning and filter element exchanges.

MONITORING REQUIREMENTS:

Daily: Check pre and post-filter pressure, and ΔP (*pressure drop*) across it while the RO is running.

MAINTENANCE:

- Replace filters every 30 days or as required if there is a ΔP (*pressure drop*) across the filter of greater than 15 psi while the RO is running; whichever comes first.
- When changing the filter, the inside of the filter housing should be wiped down with a clean cloth using either water or a mild (1%) bleach solution.

* See *System Maintenance section*



part#
SUCA000551
10" Big Blue
5 Micron Filter



part#
SUMIO00587
O-Ring for 10" Big
Blue Housing

SYSTEM COMPONENTS: 1232 RO

DESCRIPTION:

The 1232 RO is the central water producing unit between the pre-treatment and post-treatment components, producing product water for six to eight stations at 2 gallons per minute.

The **Frame** is constructed of welded steel with a durable powder-coat paint finish to reduce rust and corrosion and is mounted onto the MediPac frame.

The RO has a **Pump** that is used to raise the osmotic pressure across the thin film composite **2.5" x 40" Membranes**.

It also uses a **.03 Capsule Filter** for final filtration.

The following are additional features incorporated into the RO's control box:

- A **Digital Flush Timer** to control the frequency and duration of a flush cycle.
- A **Water Quality Monitor** to display % rejection, feed TDS, and product TDS, and alarm in a poor water quality condition.
- **Timed Operate** feature to allow the RO to run for thirty minutes prior to the operator performing daily checks.
- Interfaces with the **Interlock Wiring System** to shut the RO off when any of the pre-treatment components go into regenerate or backwash mode, and provide a visual indicator.
- Interfaces with the **Level Control System** to turn the RO off and on based on water levels in the Storage Tank.

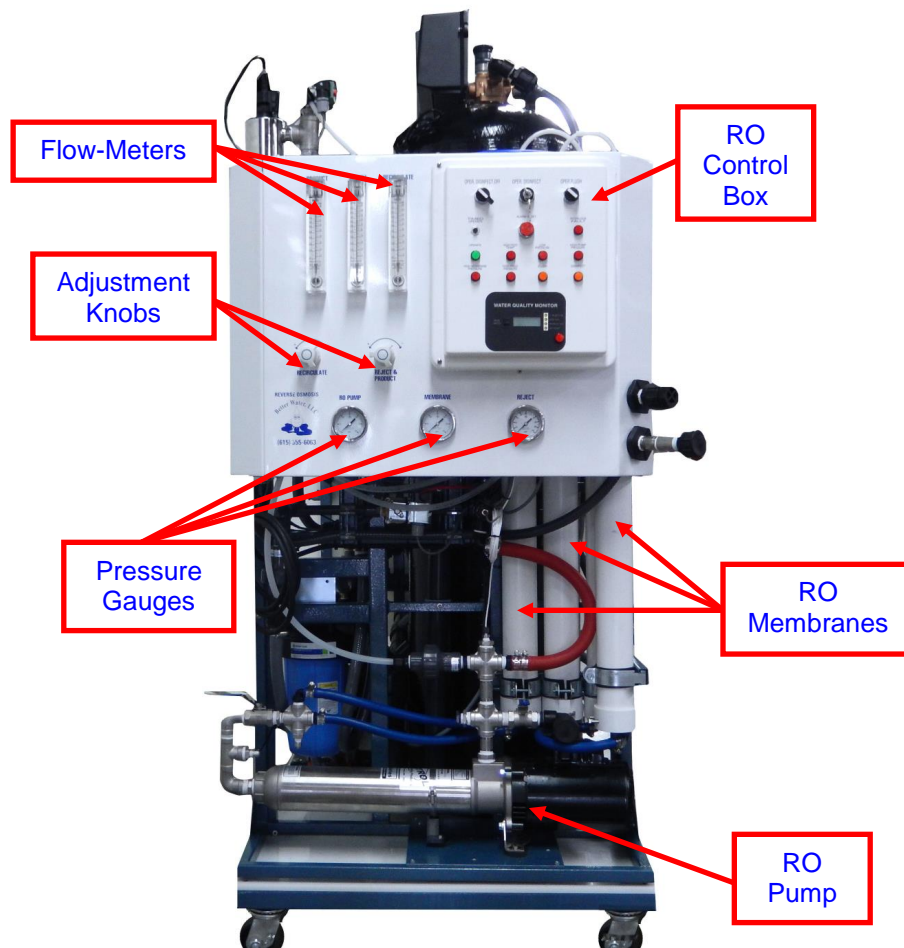

Better Water LLC; rev. Jun 2016

SYSTEM COMPONENTS: POST-TREATMENT; Repress Pump

DESCRIPTION:

The repress pump is a stainless steel, multi-stage, centrifugal pump designed for continuous duty service. It is a 3/4 HP, single phase, 115 vac pump used to maintain recirculation pressure in the post-treatment portion of the system.

MONITORING REQUIREMENTS:

Daily: Monitored to ensure desired pressure is maintained.

MAINTENANCE:

* See *System Maintenance* section for priming instructions.



part#
EQPUGRCRN3-4-1
Repress Pump

SYSTEM COMPONENTS: POST-TREATMENT; Ultra-Violet Irradiation (Post-RO)

DESCRIPTION:

The ultraviolet irradiation water disinfection unit consists of a UV lamp housed inside a fused quartz sleeve which seals the lamp from direct water contact. The sleeve, in turn, is housed in a stainless steel treatment chamber. The UV rays pass through the quartz sleeve and into the surrounding water. These UV rays alter the DNA of many common waterborne bacteria and sterilize (*prevent reproduction*) them. The low-pressure germicidal UV lamp produces a slightly shorter UV ray in concentrated form. 90% of the energy produced by this lamp has a wavelength of 254 nanometers, which will reduce many water-borne microorganisms.

MONITORING REQUIREMENTS:

Daily: This component must be monitored on a daily basis to insure the UV light is operating and the bulb is on.

MAINTENANCE:

- The UV bulb should be replaced every 12 months.
- Clean the quartz sleeve every 6 months.
- Change the quartz sleeve as needed.

Two models of UV lights have been used on the Medipac systems, which are detailed below.



part#
EQUVOO0895
UV SPV-600



part#
EQUVOO1907
UV Pro-Max 10



part#
SUUV002026
UV Bulb, SPV-600



part#
SUUV002023
UV Bulb, Pro-Max 10



part#
SUUV002027
UV Quartz Sleeve, SPV-600



part#
SUUV002022
UV Quartz Sleeve, Pro-Max 10

SYSTEM COMPONENTS: POST-TREATMENT; Pyrogen Cartridge (20", .03 micron ultra-filter)

DESCRIPTION:

This is a cartridge type filter utilized to capture bacteria, pyrogens, and endotoxins larger than .03 microns. This is considered a polishing filter. Normally, there will be a pre-filter and a post-filter gauge to measure pressure drop that indicates filter clogging. The filter housing is threaded for easy cleaning and filter element exchanges.



MONITORING REQUIREMENTS:

Daily: Check pre and post-filter pressure, and ΔP (*pressure drop*) across it while the RO is running.

MAINTENANCE:

- Replace filters every 6 months or as required if there is a ΔP (*pressure drop*) across the filter of greater than 15 psi while the RO is running; whichever comes first.
- When changing the filter, the inside of the filter housing should be wiped down with a clean cloth using either water or a mild (1%) bleach solution.

* See *System Maintenance section*



part#
SUCAPE00575
20" .03 Ultra Filter



part#
SUMIOO00589
O-Ring for 20" Big
Blue Housing

SYSTEM COMPONENTS: POST-TREATMENT; Particulate Filtration Cartridge (10" Big Blue, 5 micron filter)

DESCRIPTION:

A basic particulate filtration consisting of a 10" housing fitted with a cartridge type filter element, to trap particulate matter of 5 microns or larger when DI tanks are in use. There is a pre-filter and a post-filter gauge to measure pressure drop that indicates filter clogging. The filter housing is threaded for easy cleaning and filter element exchanges.

A short bowl is used in place of the housing and filter when DI tanks are not in use.



MONITORING REQUIREMENTS:

Daily: Check pre and post-filter pressure, and ΔP (*pressure drop*) across it while the RO is running.

MAINTENANCE:

- Replace filters every 30 days or as required if there is a ΔP (*pressure drop*) across the filter of greater than 15 psi while the RO is running; whichever comes first.
- When changing the filter, the inside of the filter housing should be wiped down with a clean cloth using either water or a mild (1%) bleach solution.

* See *System Maintenance* section



part#
SUCA000551
10" Big Blue
5 Micron Filter



part#
SUMIO00587
O-Ring for 10" Big
Blue Housing



PLFIS801951
Short Bowl with
drain for
10" Big Blue

SYSTEM COMPONENTS: Divert-to-Drain, Wall-Mounted

DESCRIPTION:

A Divert-to-Drain uses a Resistivity Monitor with an adjustable set-point to check the resistivity of incoming water. Water quality readings from the Resistivity Probe are processed by the Resistivity Monitor which in-turn either...

... opens a valve to allow water to flow through to the loop (*good water quality > 1.2 megohm*)

- or -

... closes a valve to divert the water to drain (*poor water quality < 1.2 megohm*)

The Divert-to-Drain operates as follows:

1. When the water quality is below the set-point, the Resistivity Controller directs the 3-way valve to open the TO-DRAIN side and the water will flow to drain.
2. When the water quality is good, the Resistivity Controller directs the 3-way valve to open the distribution side and the water will flow to the Loop.
3. Additionally the operator may choose to manually divert the water to drain.

This unit utilizes a Water Quality Remote Alarm Box equipped with audible and visual alarms.

MAINTENANCE:

- Manually test the DTD valve to open and close periodically.
- Set/adjust the set-point on the resistivity point as needed.



part#
EQDTD-WM-RM-2
Wall-Mounted Divert-to-Drain



part#
EQASSYWQA01844
Water Quality Remote Alarm

SYSTEM COMPONENTS: STORAGE TANK and LEVEL CONTROL SYSTEM

DESCRIPTION:

The storage tank is typically made of polyethylene, and has a conical bottom to facilitate complete draining. It is equipped with spray heads (nozzles) to continuously wash down and broadly distribute disinfectant over the inside surface. There is a sealable top hatch, and pressure regulating valve to regulate loop pressure. A submicron air filter is included to reduce microbiological contamination.

A vital part of the level control system are the proximity water level sensors used to control the RO, turning it on and off, and to activate an alarm in a low water level condition. These three sensors are stacked vertically and spaced according to the size of the storage tank.

- The bottom sensor will activate an alarm when the storage tank's water level falls below this sensor, signaling a low water level condition.
- The middle sensor will start the RO for water production when the storage tank's water level falls below this sensor.
- The top sensor will turn the RO off when the storage tank's water level reaches this sensor, signaling sufficient water is available.

The **Level Control System** is operated by RO's Tank/Direct Mode Switch, and is activated when in Tank Mode. If this switch is in Direct Mode, the level control system is deactivated causing the RO to run until manually shutoff. On a Tank Feed system the only time the RO should be placed in Direct Mode is during the disinfect procedure when it is required to raise the water level in the tank to its capacity for complete disinfection and rinsing. The MediPac Control Box has a Tank Alarm On/Off Switch which will mute an audible alarm. The alarm should be muted during disinfection since the storage tank water level will be raised and lowered several times.



MAINTENANCE:

- Replace tank vent air filter every 3 months.



part#

SUCA000557

Tank Vent Filter, .2 micron

Better Water LLC; rev. Jun 2016

SYSTEM COMPONENTS: REMOTE ALARM BOX

DESCRIPTION:

The RO Remote Alarm Box is a molded plastic box, usually located on the patient floor, in a position where it can be easily seen by clinic personnel during normal work duties. The box is equipped with audible and visual alarms that monitor the RO and Storage Tank water level.

The Remote Alarm Monitoring Box requires no external power supply, but receives 24vac power and signals from the RO which it is monitoring. This box has 2 RED lights; one that will illuminate when the RO goes into an alarm condition and one when the water level in the storage tank falls below the low-level sensor. The AMBER light will illuminate and flash when the RO is in Disinfect Mode.

AAMI standards require that the RO alarms be audible in the patient area. If the RO is located close enough to be heard in the patient area, the remote alarm may be omitted.

This device is automatic and requires no daily start-up procedures.

This is a monitoring device; therefore it will monitor the RO constantly, as to the state of the water. The probability of failure is remote; however, should the Remote Alarm Box fail, the clinic personnel may not be aware of the changes in water quality.



part#
EQASSYNSMB01601
Remote Alarm Box

SYSTEM COMPONENTS: DISINFECT TANK

The Disinfect Tank is made of a non-corrosive, molded plastic with a lid. The tank is equipped with 2 ports on the top (*side*) and a single port on the bottom (*side*), and all the necessary hoses, valves and fittings. *Some assembly required.*

The hoses supplied with the Disinfect Tank will connect to the top (*side*) ports on the Disinfect Tank and the other ends will connect to the RO Product and Drain. The third hose will connect the bottom (*side*) port to the Clean/Disinfect Valve on the RO.

See the **Disinfect Section** for complete instructions.



part#
EQASSYDISTANK
Disinfect Tank Assembly

GENERAL OPERATION

Before you start using this device, operators must read and understand this manual in its entirety. This manual of Operator's Instructions describes in considerable detail the steps and procedures required to **safely** operate this device. With proper operation, maintenance, and care, this device should give you years of reliable service.

It is **unsafe** to operate this device without a basic understanding of water treatment and a thorough understanding of the contents of this manual. Inadequately treated water for hemodialysis poses a severe threat to the health and safety of hemodialysis patients. Education and training of the staff in these facilities is critical given the technically complex subject of water treatment. Guidelines and other related information are available from:

- Food and Drug Administration (FDA)
- National Association of Nephrology Technicians/Technologists (NANT)
- Association for the Advancement of Medical Instrumentation (AAMI)

Incoming tap water contaminants, temperature, pH, pressure, and flow-rates have a direct impact on the quality and quantity of the RO output. The operator must be aware of changing tap water conditions. This can be easily accomplished with good, two-way communications with the local municipal water supplier and with routine testing of the tap water.

This manual should be used in conjunction with the [1232 RO Operator Manual](#), which contains more detailed information specific to the 1232 RO.

VALVES LEGEND and OPERATION

1. Blend-Valve By-pass Valve

Open to bypass the Blend Valve

* CLOSED during normal operation

2. City Boost Pump Inlet Valve

Open to allow water into the City Boost Pump

* OPEN during normal operation

3. City Boost Pump By-pass Valve

Close to bypass the City Boost Pump

* CLOSED during normal operation

4. Water Softener Inlet Valve

Open to allow water into Water Softener

* OPEN during normal operation

5. Water Softener By-pass Valve

Open to bypass the Water Softener

* CLOSED during normal operation

6. Water Softener Outlet Valve

Open to allow water to exit from the Water Softener

* OPEN during normal operation

7. Worker Carbon Tank Inlet Valve

Open to allow water into Worker Carbon Tank

* OPEN during normal operation

8. Worker Carbon Tank Outlet Valve

Open to allow water to exit from the Worker Carbon Tank

* OPEN during normal operation

9. Polisher Carbon Tank Inlet Valve

Open to allow water into Worker Polisher Tank

* OPEN during normal operation

10. Polisher Carbon Tank Outlet Valve

Open to allow water to exit from the Polisher Carbon Tank

* OPEN during normal operation

11. Pre-Treatment UV Light Inlet Valve

Open to allow water into Pre-Treatment UV Light

* OPEN during normal operation

12. Pre-Treatment UV Light By-pass Valve

Open to bypass the Pre-Treatment UV Light

* CLOSED during normal operation

13. Pre-Treatment UV Light Outlet Valve

Open to allow water to exit from the Pre-Treatment UV Light

* OPEN during normal operation

14. RO Inlet Valve

Open to allow water into the RO
 * OPEN during normal operation

15. Post-RO and Storage Tank Emergency By-pass Valve (DI Supply)

Open to bypass the Storage Tank and allow DI Tank Supply
 * CLOSED during normal operation

16. Boiler Drain

Open to allow water to drain pre-treatment
 * CLOSED during normal operation

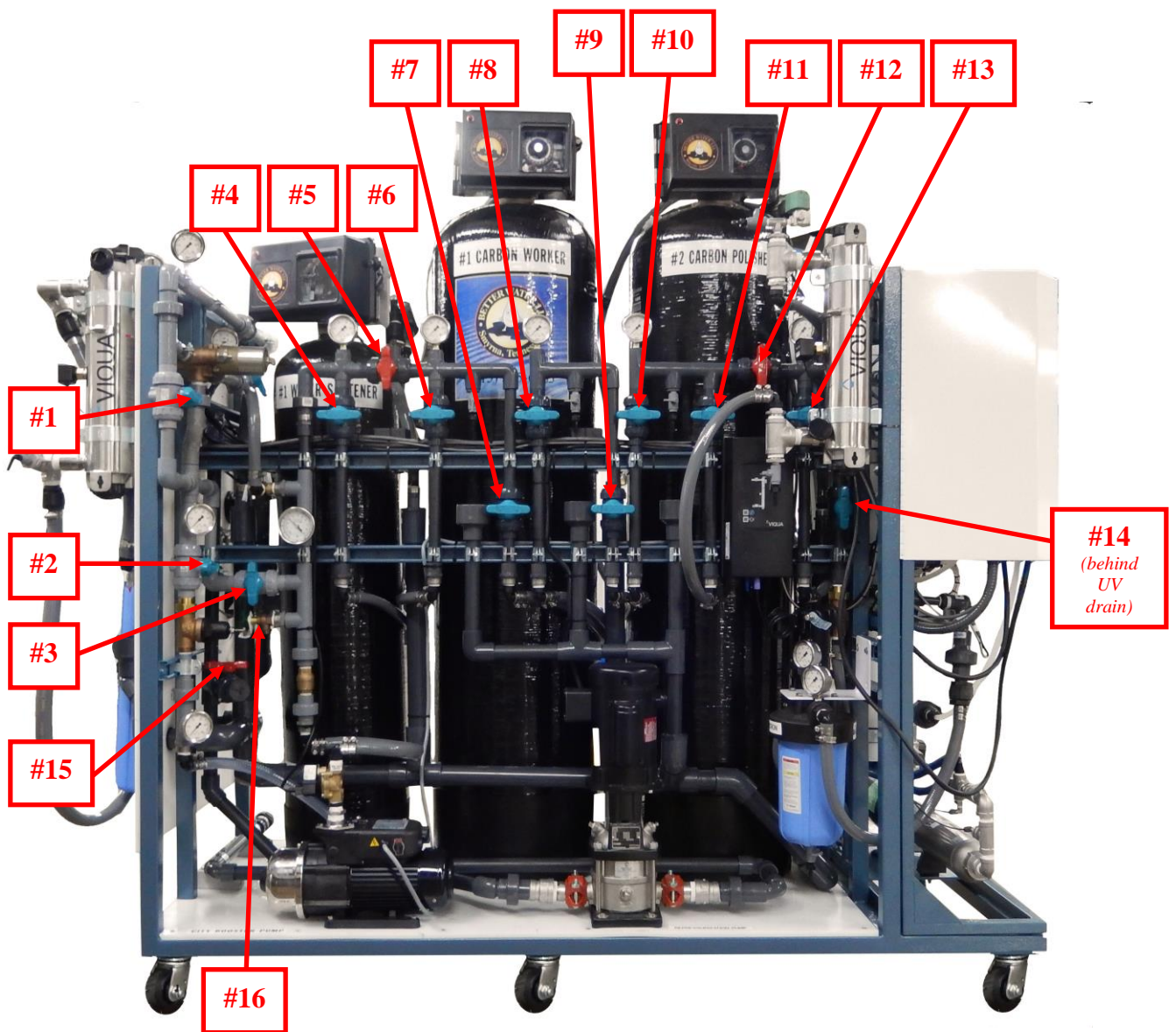

17. Cold Water Inlet Valve

Open to allow cold water into the system
* OPEN during normal operation

18. Hot Water Inlet Valve

Open to allow hot water into the system
* OPEN during normal operation

19. DI Water Inlet Valve

Open to allow water into DI Tank
* OPEN during normal operation and when DI Tanks in use

20 DI Water Outlet Valve

Open to allow water to exit from DI Tank
* OPEN during normal operation and when DI Tanks in use

21. DI By-Pass Valve

Open to by-pass DI Tank Header
* CLOSED during normal operation

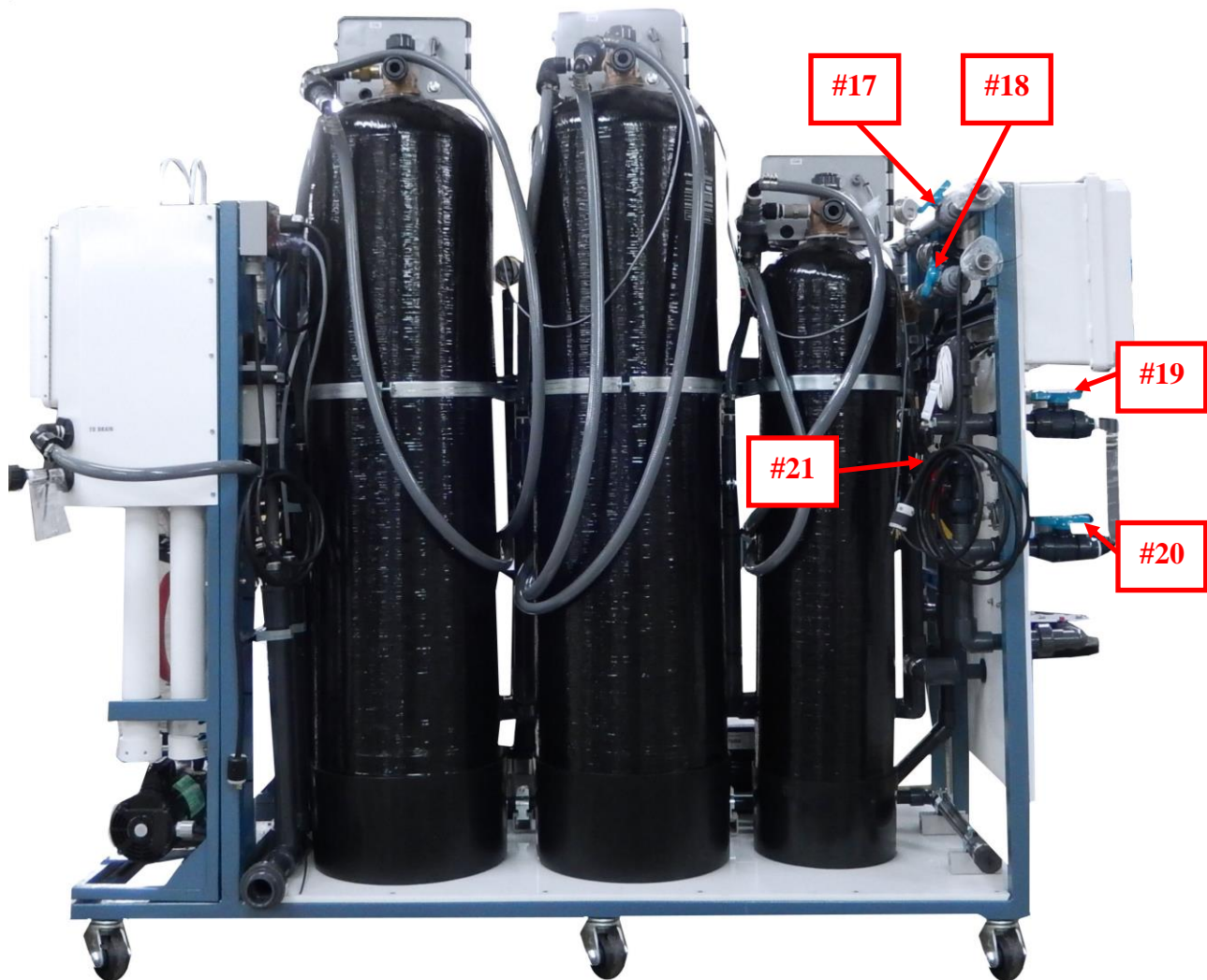

DAILY START-UP

During normal operation, the RO would be set in **FLUSH MODE** at end-of-day, and therefore should be in this mode when ready to start-up at the beginning of a new day.

1. Verify that all valves are in the correct position for daily operation.

2. Verify the **City Booster Pump** is **ON**:

- For the Grundfos MQ Series... if the PUMP ON Light is not illuminated then press the **ON/OFF Button** located on the pump.

- For the Walrus TQ-800... verify that the POWER SWITCH located on the pump is **ON**.

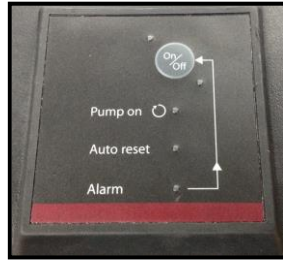

Grundfos MQ Series



Walrus TQ-800 Pump

3. Verify the **Post-Treatment** is **ON**:

On the MediPac Control Panel...

a. Verify that the **REPRESSURIZATION PUMP Switch** is in the **ON** position.

b. Verify that the **TANK ALARM Switch** is in the **ON** position.



4. Start the RO:

a. Check the RO CONTROL PANEL:

- All alarm lights should be **OFF** and **NO** audible alarm should be sounding.
 - If any one or more of the alarm lights are **ON** and/or an audible alarm is sounding, press the **ALARM RESET Button**. All alarm lights should go out and audible alarms should stop sounding.



b. Verify that the **OPERATE-DISINFECT key switch** is in the **OPERATE** position.

If this switch is in the DISINFECT position, you MUST verify that the RO does NOT contain any disinfecting solution BEFORE proceeding to the next step.



WARNING
 Disinfectants can cause serious injury or death to patients undergoing hemodialysis treatment.

c. Verify the **OPERATE-DISINFECT-OFF switch** is in the **OPERATE** position.

If the switch is in the DISINFECT or OFF position, see step 2 and the warning above.



d. If you must reset the switches listed above, the alarm lights will illuminate and the audible alarm will sound, press the **ALARM RESET Button** to return the alarms to normal.



e. Set the **OPERATE-FLUSH switch** to **OPERATE**.



f. Press the **TIMED OPERATE Button**.

- *NOTE: Should the Storage Tank level have dropped to the middle proximity sensor, the RO would have automatically started upon turning the switch from FLUSH to OPERATE.*



The Quality Purge cycle will commence. An air purge cycle will run for approximately 30 seconds. Then the Product Purge Valve will open and run to drain until the water quality is above the set point.

NOTE

After approximately 30 seconds the RO pump will start, and at the same time, the Water Quality Alarm light will illuminate. This is a normal function to advise you that the first water produced by the RO is being routed to drain until the water quality equals or surpasses the set-point on the Water Quality Monitor. This purge cycles will take approximately two minutes.

After the Purge Cycles have completed, the RO should be operating within the following parameters:

- Membrane pressure should read: **75-250 psi**
- There is no standard for Reject Pressure
- Product Pressure should read: **less than 25 psi** on tank feed systems and **less than 70 psi** on direct feed systems
- The water quality should be **above the set-point (90%)**

c. If the Repress Pump is not running, press and hold the **PUMP START Button** for 5 seconds and release when the repress pump starts.

MONITORING PROCEDURES

1. The MediPac **must be monitored** on a **daily** schedule by a **qualified technician** using a **Quality Assurance Checklist**. An example checklist is provided in the **Appendix A** of this manual and may be reproduced for use.

2. The filter gauges should be checked with water flowing when there is demand for purified water.

DAILY SHUTDOWN

1. Turn the **RO Control Box, OPER-FLUSH Switch** to **FLUSH**.

* *The RO will go into Flush Mode at the pre-set time.*

NOTE: *The Pre-Treatment Carbon Filters backwash and the Water Softener will regenerate at the pre-set times.*

GENERAL CLEANING and DISINFECTING INFORMATION

To perform at peak efficiency the Medipac RO must periodically be cleaned and disinfected, and the Post-Treatment disinfected. These procedures are a crucial part of ensuring optimum performance.

The **Cleaning Process (RO Only)** is designed to remove mineral deposits that may build-up on internal surfaces.

The **Disinfecting Process** is designed to significantly reduce bacteria and endotoxins that may build-up in the water and on the internal surfaces in the form of bio-film. The importance of regular and frequent disinfection cannot be minimized due to the risk associated with bacteria proliferation.

CLEANING and DISINFECTING FREQUENCY

As the manufacturer, Better Water LLC recommends the following:

- **If membrane fouling is indicated:** Low pH Clean with BWI-1000 and Disinfection with Minncare
- **Monthly:** Low pH Clean with BWI-1000 and Disinfection with Minncare (*in that order*).
- **Quarterly:** Low pH Clean with BWI-1000, High pH Clean with BWI-2000, and Disinfection with Minncare (*in that order*).
- **If the RO has been in storage** and should have been loaded with preservative, then after rinsing of preservative the following should be done: Low pH Clean with BWI-1000, High pH Clean with BWI-2000, and Disinfection with Minncare (*in that order*).

Cleaning and disinfecting should be initiated if membranes are fouled indicated when...

- the **Product Flow decreases** and the **Reject Flow increases**, and the two cannot be adjusted to design specifications
- the **Pump Pressure increases**, the **Membrane Pressure increases**, and the **Reject Pressure decreases**
- the **Quality Monitor** indicates a **continuous decline in water quality**
- The RO may require more frequent cleaning and disinfecting, which is ultimately the Medical Director's responsibility to determine and is typically based on water testing.

RESIDUAL CHEMICAL TESTING

Users should refer to the chemical agent manufacturer to determine the appropriate method for testing for residual chemical substances in the water after cleaning and disinfecting. The water must be clear of detectable levels of cleaning and disinfecting agents prior to use with patients

CAUTION

If performing both Low pH and High pH cleanings, always perform the Low pH first, otherwise the membrane can be damaged.

WARNING

DO NOT use "Hydrochloric Acid" based products for disinfection and/or cleaning the RO as these can damage the internal components and will void the Limited Warranty. Use only the recommended products as previously detailed.

Also DO NOT use "Sodium Hypochlorite" (bleach) based products as these will damage the RO's membrane.

Changes in the tap water pH, TDS, temperature, or pressure, can also cause significant changes in the overall performance of the RO.



OUTSOURCED WATER TESTING

A laboratory specified by the physician or Medical Director should perform chemical and microbial analyses as outlined in the current AAMI/ISO Standards to determine the current compatibility of the RO with the feed water and the suitability of the system for providing product water meeting the AAMI requirements. This should be performed annually or more often if needed but, it is ultimately at the discretion of the physician or Medical Director.

Water samples for this type of testing should always be taken from the final product water.

CLEANING and DISINFECTING AGENTS

MINNCARE: DISINFECTING AGENT *(replaces Renalin or Actril)*

- ***Disinfectant cannot be used on devices with brass fittings!***
- **Application:** RO and system disinfectant
MUST use BWI-1000 Acid Cleaner BEFORE using Minncare.
For routine maintenance, there should be a dwell time of 2-4 hours.
If a highly contaminated condition exists, dwell time can be increased to 12 hours.
- **Dilution:** 750 cc's to 20 gallons of RO water
- **1% Test Strips;** part#: **SUMCOO00577** 
- **Residual Test Strips** used to confirm rinsing; part#: **SUMCOO00576** 



part#
SUMCOO00575

BWI-1000 ACID CLEANER: *(replaces Minnclean AC & Citric Acid)*

- Cleaner may be used with brass fittings
- **Application:** For removing mineral scale in membrane applications
MUST first use BWI-1000 Acid Cleaner BEFORE using Minncare, BWI-2000 Alkaline Cleaner
- **Dilution:** 1 pound of BWI-1000 Acid Cleaner to 15 gallons of RO water



part#
SUMCOO00572

BWI-2000 ALKALINE CLEANER: *(replaces Minnclean TF & Organoclean)*

- Cleaner may be used with brass fittings.
- **Application:** For removing oil, grease, biological matter and grime on Thin Film Composite membranes.
MUST first use BWI-1000 Acid Cleaner BEFORE using BWI-2000 Alkaline Cleaner.
- **Dilution:** 1 pound of BWI-2000 Alkaline Cleaner to 15 gallons of RO water.



part#
SUMCOO00571

NOTE

The label on all Minncare and BWI products will have mixing directions.

DISINFECTING and CLEANING PROCEDURE

The procedure below applies to the Low pH cleaning, High pH cleaning, and disinfection.

WARNING

Chemical cleaners and disinfectants can cause serious injury or death.

Proper protective equipment must be used.

The preparation of these chemical solutions must be done in accordance with the specifications established for the particular chemical.

These chemical solutions must be handled in accordance with their Material Safety Data Sheet (MSDS).

These procedures should be performed by trained and qualified technicians.

This is a step phase procedure; first clean or disinfect the RO, then secondly disinfect the post-treatment, storage tank, and distribution loop.

DISINFECT/CLEAN the RO

1. Before beginning cleaning or disinfection rinse the Disinfect Tank with RO water and drain thoroughly.

2. Prepare the Disinfect Tank for hook up to RO.

a. Connect the **Product Disinfect Hose** from the **Storage Tank's 3-Way Valve** to the **Park fitting on the Disinfect Tank**, then turn the **Storage Tank's 3-Way Valve** to disinfect tank.

b. Make sure the feed valve at the bottom of Disinfect Tank is closed.

c. Place the RO in "Direct-Feed" mode, by opening the RO Control Box and turning the **Tank/Direct Switch** to **DIRECT**.

d. Set the RO in normal Operate Mode

- Turn the **OPERATE-DISINFECT-OFF Switch** to **OFF** then turn it to **OPERATE**

- Set the **OPERATE-DISINFECT key Switch** to **OPERATE**

- Set the **OPERATE-FLUSH Switch** to **OPERATE**



e. Then push the **ALARM RESET Button** to start the RO



f. Fill tank with 15 gallons (*approximately 14 inches*) of **Product** water for the Low and High pH cleaning. For Disinfection fill tank with 20 gallons (*approximately 18 inches*) of **Product** Water.

3. When **Disinfect Tank** has been filled with **Product** water, connect the supplied 3/4" **Reject Hose** from the **Disinfect Tank** to the **RO Drain**.

a. Next connect the supplied ¾" **Feed Hose** from the **Disinfect Tank** to the **Clean/Disinfect Ball Valve** located at the base of the pump.

b. Before completely tightening the **Park Fitting** to **Clean/Disinfect Ball Valve** open the **Disinfect Tank Ball Valve** to prime the feed hose.

c. When water starts trickling out of the **Park Fitting** then tighten the **Park Fitting**.

- **NOTE:** If the Disinfect Tank Feed Hose hasn't been properly primed the pump will air lock and could cause damage to the pump.

4. Before adding the Cleaners or Disinfectant start the RO in Disinfect.

- Set the **OPERATE-DISINFECT-OFF Switch** to **DISINFECT**

- Set the **OPERATE-DISINFECT Key Switch** to **DISINFECT**

- Set the **OPERATE-FLUSH Switch** to **OPERATE**

* The RO will start up immediately.

- Verify flow by looking at the Product and Reject Flow Meters and visually see if water flowing back in to the Disinfect tank through the Product and Drain hoses with no leaks.



5. Before beginning cleaning with Low or High pH cleaners, it is recommended that a baseline pH reading be taken from the Product returning into the Disinfect tank.

6. If CLEANING...

a. Add 1 lb or 454 grams of either Low pH (*BWI-1000 Acid Cleaner*) or High pH (*BWI-2000 Alkaline Cleaner*) cleaners to the Disinfect tank. If using a graduated cylinder measure, 340 mls of Low pH cleaner (*BWI-1000*) and 490 mls for High pH cleaner (*BWI-2000*).

b. Circulate the cleaners for 15 minutes.

- During circulation, while cleaning, the operator should verify the pH of the cleaner used by checking the Product returning back to Disinfect tank. For Low pH cleaner the pH should read less than 3 pH units. For High pH cleaner the pH should read greater than 9 pH units.

c. **Cleaner Dwell Times.** For **Cleaners** there is no recommended dwell time.

d. Rinse Cleaners from the RO

- After the 15 minute circulation, shut the RO off.

- Set the **OPERATE-DISINFECT-OFF Switch** to **OFF**



- Connect the **Storage Tank Disinfect Hose** to drain.

- Disconnect the supplied ¾" **Drain Hose** from RO to the **Disinfect Tank** and reconnect the RO **Drain Hose**.

- Close the **Disinfect Tank Ball Valve**.

- Remove the ¾" **Disinfect Tank Feed Hose** from the **Clean/Disinfect Ball Valve** and close the **Clean/Disinfect Ball Valve on the Pump**.

- Start the RO in normal Operate mode.

- Set the **OPERATE-DISINFECT-OFF Switch** to **OPERATE**

- Set the **OPERATE-DISINFECT Key Switch** to **OPERATE**

- Set the **OPERATE-FLUSH Switch** to **OPERATE**



- Push the **ALARM RESET Button** to start the RO.



- Run the RO until the pH from the Product returns to baseline pH that was observed before cleaning.

- Place the RO in "Tank-Feed" mode, by opening the RO Control Box and turning the **Tank/Direct Switch** to **TANK**.

7. If DISINFECTING...

- Add 750 mls of either Renalin or MinnCare to the Disinfect tank.

- Circulate the disinfectant for 15 minutes.

- During circulation while disinfecting with Renalin or MinnCare, a 1% Peracetic acid test strip should be used to verify that the Product returning back to the Disinfect tank is at 1%.

- After the 15 minute circulation, shut the RO off

- Set the **OPERATE-DISINFECT-OFF Switch** to **OFF**



- Disinfectants Dwell Times.** For **Disinfectants** such as Renalin or MinnCare a 30 minute to 2 hour dwell is recommended.

- Rinse Disinfectant from the RO.**

- Connect the **Storage Tank Product Hose** to drain.

- Disconnect the supplied 3/4" **Drain Hose** from RO to the **Disinfect Tank** and reconnect the RO drain hose.

- Route Product Water to Drain.

- Close the **Disinfect Tank Ball Valve**.

- Remove the 3/4" **Disinfect Tank Feed Hose** from the **Clean/Disinfect Ball Valve** and close the **Clean/Disinfect Ball Valve on the Pump**.

- Start the RO in normal Operate mode.

- Set the **OPERATE-DISINFECT-OFF Switch** to **OPERATE**

- Set **OPERATE-DISINFECT Key Switch** to **OPERATE**

- Set **OPERATE-FLUSH Switch** to **OPERATE**



- Then push the **ALARM RESET Button** to start the RO.



- Run the RO until the Disinfectant has been rinsed from the RO

- To verify that the disinfectant has been rinsed out from the Product a Residual Peracetic acid test strip should be used.

- If the residual test strip shows a positive continue rinsing to drain until a negative reading is obtained.

- If the residual test strip shows a negative reading has been obtained then turn off the RO for a **Rebound Break**.

Rebound Break

The Rebound Break is for 15-20 minutes. This **is highly recommended** as some residual disinfectant could still be present in the membranes even if a negative result was obtained during rinsing. After the rebound break time has been completed (15-20 min), restart the RO in normal Operate mode again and recheck for Residual. If the residual is positive, continue to rinse until a negative result is achieved. Once the residual is negative, turn off the RO and allow for another Rebound Break of 15-20 minutes. Turn on the RO and re-check for residual. Repeat this process as many times as necessary until a negative Residual is obtained after the rebound break.

- Place the RO in “Tank-Feed” mode, by opening the RO Control Box and turning the **Tank/Direct Switch** to **TANK**.

DISINFECT the POST-TREATMENT, STORAGE TANK, and DISTRIBUTION LOOP

* Complete disinfect procedure of the RO first.

1. Confirm that there is no need for purified water.
2. Notify all necessary personnel that the system will be disinfecting.
3. Fill the Storage Tank with the appropriate amount of RO water for the disinfect process.

4. Turn the RO and Repress Pump OFF...

- Turn the RO's **OPERATE-DISINFECT-OFF Switch** to **OFF**
- Turn Repress Pump off, by turning the **MediPac's REPRESSURIZATION PUMP Switch** to **OFF**



5. If D.I. tanks are on-line...

- **CLOSE DI Inlet Valve** and **DI Outlet Valve**.
- Disconnect them from the system.
- Connect jumper hose(s) from DI Inlet Valve to DI Outlet Valve.
- **OPEN DI Inlet Valve** and **DI Outlet Valve**.

6. If a 5 micron filter is installed in the post-treatment filter housing (post-DI)...

- **CLOSE DI Outlet Valve**.
- Remove this filter and discard it.
- Install the false cartridge tube.
- **OPEN DI Outlet Valve**.

7. Remove the Storage Tank Lid and add appropriate amount of disinfectant to storage tank (see **General Cleaning/Disinfecting Information** section in this manual).

- Replace Storage Tank Lid.

8. Start the Repressurization Pump by...

- Set the MediPac's **REPRESSURIZATION PUMP Switch** to **ON**
- Press and hold the **PUMP START Button** until the repress pump starts
- Allow this to recirculate for 15-20 minutes.
- After 15-20 minutes, verify at each of the stations and at the **Loop Return Sample Port** that there is disinfectant present, then let disinfectant dwell (*circulate*) in the system for 30 minutes to 2 hours.

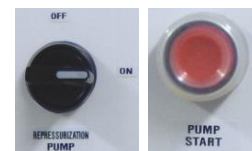

9. During the 30 minute to 2 hour dwell (*circulate*) time, open each of the **Sample and Drain Ports**, and all **Points-of-Use in the Loop**, in the Post-Treatment to allow disinfectant to flow through them for at least 30 seconds, closing when finished.

10. **OPEN** the **Loop Return to Drain Valve** and **CLOSE** **Loop Return to Storage Tank Valve**, and let the Repressurization Pump empty the storage tank and loop.
- *The pump will automatically turn off when there is no more water/disinfectant in the storage tank.*

11. Remove the 3/4" Product Disinfect Hose from the Drain and connect to Loop Return Header.
- **OPEN** **Loop Return Clear-Out Valve**.
- **OPEN** **Storage Tank Drain Valve**.

12. Place the RO in "Direct-Feed" mode, by opening the RO Control Box and turning the **Tank/Direct Switch** to **DIRECT**.

13. Start the RO in normal Operate mode.
- Set the **OPERATE-DISINFECT-OFF Switch** to **OPERATE**
- Set **OPERATE-DISINFECT Key Switch** to **OPERATE**
- Set **OPERATE-FLUSH Switch** to **OPERATE**
- This will start the RO and produce water to rinse out the loop and storage tank.
- Continue rinse until there is no residual sampling reveals no disinfectant residual at the **Storage Tank Drain**.



14. Turn the RO OFF...
- Set the RO's **OPERATE-DISINFECT-OFF Switch** to **OFF**



15. Remove hose from between **Storage Tank** and **Loop Return Clear-Out Valve**.

16. **CLOSE** the **Storage Tank Drain Valve**, and turn the **Storage Tank's 3-Way Valve** back to Storage Tank.

17. Turn the RO ON...
- Set the RO's **OPERATE-DISINFECT-OFF Switch** to **OPERATE**
- Fill the storage tank until water is flushed out of the trapped overflow.



18. **OPEN** the **Loop Return to Drain Valve**.

19. Start the Repressurization Pump by...
- Set the MediPac's **REPRESSURIZATION PUMP Switch** to **ON**
- Press and hold the **PUMP START Button** until the repress pump starts

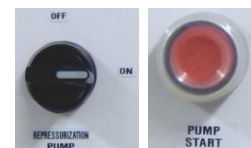

20. Run in this mode until the Loop Return Sample Port is clear of residual disinfectant.

21. After all residual has been rinsed out of the system, and verified at each point of use station and all Post Treatment Sample Ports, put the system back into normal operation...

- **CLOSE** the **Loop Return to Drain Valve**
- **OPEN** the **Loop Return to Storage Tank Valve**
- Set RO's **DIRECT/TANK Switch** back to **TANK**.
- Verify that the Storage Tank is full
- Verify the MediPac's Repressurization Pump is operating

- If DI Tanks in use...
 - Reconnect the DI tanks to the DI Inlet Valve and DI Outlet Valve
 - Open the appropriate DI valves
 - Reinstall Post-Treatment 5 micron filter for DI polishing
- Place the RO in "Tank-Feed" mode, by opening the RO Control Box and turning the **Tank/Direct Switch** to **TANK**.

SANITIZING the SANITARY SAMPLE PORTS

Sanitize the sanitary sample ports immediately BEFORE each sampling operation.

1. Turn the port stem to the left to open and allow a full flow of liquid to pass out of the port for 1-2 minutes. Then close the port by turning the stem to the right.
2. Fill a 20 ml plastic polypropylene syringe with at least 10 ml of 70% ethanol, 90% isopropyl alcohol, or 3% hydrogen peroxide solution. Attach the port-needle to the syringe.
3. Insert the needle all the way into the port through the stem opening, and express most of the sanitizer into the port. Allow a few milliliters to flow out of the port outlet.
4. As the needle is removed from the opening, squirt the remaining few milliliters of sanitizer over the outer surface of the stem.
5. When ready to sample, open the port for 1 to 2 minutes to allow product water to rinse the residuals and any endotoxins from the sample port before sampling.



WATER LEAK DETECTOR

The water leak detector is composed of two parts. The first is a **control console** which is hardwired into the control box, with the second being a **remote surface probe** which lays flat on the floor near the rack. All that is required to signal an alarm condition is a film of moisture forming a bridge between the two metallic contacts on the remote surface probe. It was designed to detect water only (*distilled or deionized water cannot be detected*). As sensitive as it is, it will not alarm due to high humidity or condensation.

If the detector senses water an audible alarm will sound, the main water shutoff solenoid will close, which turns off all water to the Pre-Treatment system, and the city booster pump will turn OFF. Once dry again, the alarm will be silenced and the main water shutoff solenoid will re-open restoring water flow once again.

SILENCING THE WATER LEAK DETECTOR ALARM

In the event the water leak detector senses water and sounds the alarm there are two ways to silence the alarm:

UNPLUG the 1232 RO

- Turn the **OPERATE-DISINFECT-OFF Switch** on the 1232 RO Control Box to **OFF**.
- Unplug the 1232 RO's power cord from the electrical receptacle.
 - This will silence the alarm, but the main water shutoff solenoid will remain closed, and the city booster pump will turn OFF.
- Determine the source of the water that caused the alarm and correct the problem.
- Lift and dry the remote surface probe with a clean dry cloth or paper towel, then return to its original location.
- Once the condition that caused the alarm has been corrected, plug the 1232 RO's power cord back in, and turn the **OPERATE-DISINFECT-OFF Switch** to **OPERATE**.

DRY THE REMOTE SURFACE PROBE

- Determine the source of the water that caused the alarm and correct the problem.
 - If a simple spill, then clean up the water.
 - If a leak, fix the leak at its source. This may require turning off the incoming water.
- Lift and dry the remote surface probe with a clean dry cloth or paper towel, then return to its original location.
 - After a few seconds, this will silence the alarm and re-open the main water shutoff solenoid valve.

NOTE: Make sure if the problem was a leak, to correct the problem or turn off the incoming water prior to drying off the remote surface probe since when dry it will re-open the main water shutoff solenoid if the 1232 RO has power.



Remote Surface Probe and connecting cable

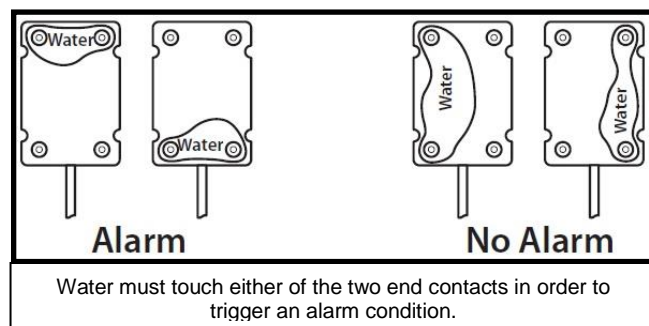

SWITCHING TO TEMPORARY DI

*Reference the **VALVES LEGEND and OPERATION** section, previously detailed in this manual for visual representation and valve numbers corresponding to the instructions below.

CONNECTING DI TANKS

1. Turn the RO and Repress Pump OFF...

- Turn the RO's **OPERATE-DISINFECT-OFF Switch** to **OFF**
- Turn Repress Pump off, by turning the MediPac's **REPRESSURIZATION PUMP Switch** to **OFF**



2. **CLOSE** the Repressurization Pump Inlet Valve (*bottom of the Storage Tank*).

3. By-pass the Water Softener by **CLOSING** the Water Softener Inlet Valve (#4) and Water Softener Outlet Valve (#5), and **OPENING** the Water Softener By-Pass Valve.

* This step is not required, but by-passing the softener will help lengthen the life of the DI resin.

4. Remove the **Short Bowl or False Cartridge** from the **Post-Treatment 5 Micron Post-DI Filter** and install the **10" Big Blue Housing** and **5 Micron-10" Filter**.

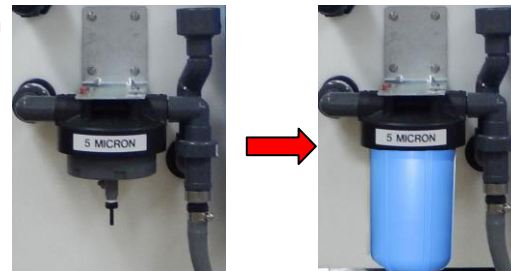

5. **CLOSE** DI Water Inlet Valve (#19) and DI Water Outlet Valve (#20).

6. **CLOSE** the Loop Return Valve at the end of the loop at the Storage Tank.

7. **CLOSE** RO Inlet Valve (#14).

8. **OPEN** the Drain Port on the Pre-Treatment 5 Micron Filter to relieve system pressure.

9. Disconnect the hose that goes between the **Pre-Treatment 5 Micron Filter** and the **RO**, at the **RO Inlet Connection**.

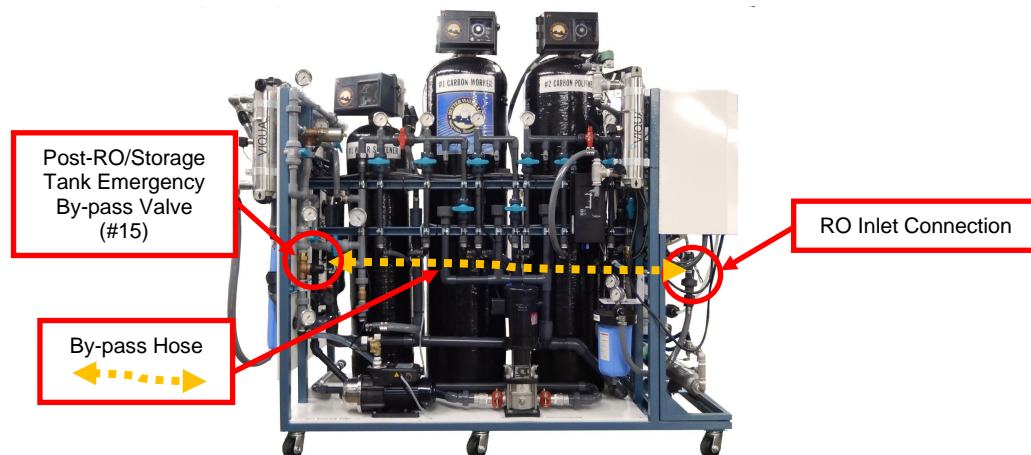

10. Connect a **By-pass Hose** from that **RO Inlet Connection** to the **Post-RO and Storage Tank Emergency By-pass Valve (#15)**.

11. Remove the **Jumper Hose** between **DI Water Inlet Valve (#19)** and **DI Water Outlet Valve (#20)**.

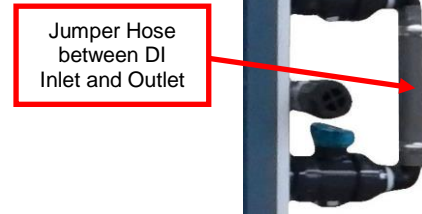

12. Move **DI Tank#1** and **DI Tank#2** into place, within hose length of the MediPac.

13. Install **Resistivity Alarms** into the outlet side each DI Tank.

- If the Resistivity Alarms are equipped with **Remote Alarms**, connect them as well.

14. Connect hoses between...

- **DI Water Inlet Valve (#19)** to **DI Tank#1 Inlet**
- **DI Tank#1 Outlet** to **DI Tank#2 Inlet**
- **DI Tank#2 Outlet** to **DI Water Outlet Valve (#20)**

15. **OPEN** RO Inlet Valve (#14).

16. **OPEN** Post-RO and Storage Tank Emergency By-pass Valve (#15) and check for leaks.

17. **OPEN** DI Water Inlet Valve (#19).

18. **OPEN** the sample/drain port on DI Tank#2 to allow water to flow to purge all air from both DI Tanks. Leave open until water runs clear, and air purged, then close.

19. **OPEN** DI Water Outlet Valve (#20).

20. Verify that **DI By-pass Valve (#21)** is **CLOSED**.

21. Turn the **Divert-to-Drain ON**.

22. DI tank water is now **ONLINE**. Monitor the tanks' Resistivity Alarms and the Divert-to-Drain Resistivity Monitor for tank exhaustion.

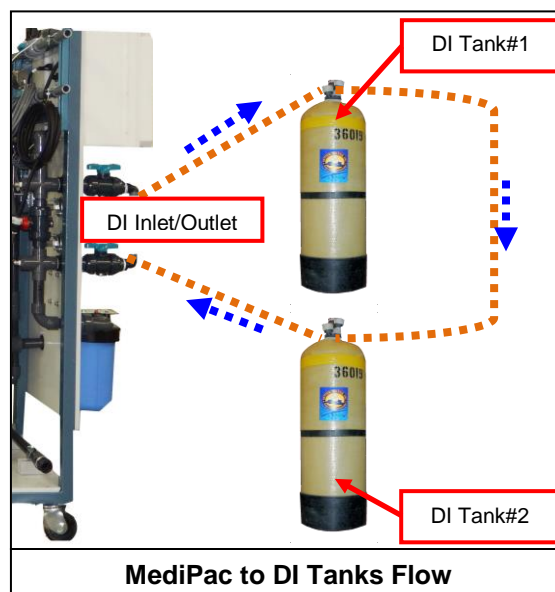

SWITCHING DI TANK#1 WHEN EXHAUSTED

** The following procedure details how to swap out the first DI Tank when exhausted, by moving DI Tank#2 to the DI Tank#1 position and put a new DI Tank into the second position. If desired both DI Tanks can be replaced at the same time by making simple modifications to the steps below.*

1. **CLOSE** DI Water Inlet Valve (#19) and DI Water Outlet Valve (#20).
2. **OPEN** the sample/drain port on DI Tank#1 to depressurize, and then **CLOSE**.
3. Disconnect the hoses between...
 - DI Water Inlet Valve (#19) and DI Tank#1 Inlet
 - DI Tank#1 Outlet and DI Tank#2 Inlet
 - DI Tank#2 Outlet and DI Water Outlet Valve (#20)
4. Move the DI Tanks as follows:
 - Move the exhausted DI Tank#1 out of position
 - Move DI Tank#2 to the first position to become DI Tank#1
 - Move a new DI Tank#2 into the second position to become DI Tank#2
5. Reconnect the hoses between...
 - DI Water Inlet Valve (#19) and DI Tank#1 Inlet
 - DI Tank#1 Outlet and DI Tank#2 Inlet
 - DI Tank#2 Outlet and DI Water Outlet Valve (#20)
6. **OPEN** DI Water Inlet Valve (#19).
7. **OPEN** the sample/drain port on DI Tank#2 to allow water to flow to purge all air from both DI Tanks. Leave open until water runs clear, and air purged, then close.
8. **OPEN** DI Water Outlet Valve (#20).

SYSTEM MAINTENANCE, General

Maintenance Task	Frequency (more often if needed)	Notes
Check the system for leaks	Daily	Visual Inspection
Monitor the system for unusual sounds	Daily	Auditory Inspection
Clean external surfaces	Weekly	Use a soft, damp towel or sponge. (DO NOT USE BLEACH)
Record operational values, ie. flows, pressures, temperature, etc.	Daily or more often as required by the facility	Record on a Pre-Treatment Daily Checklist
Refill brine tanks with salt	Prior to salt level falling below 50% in the brine tank	Do not use "rock salt". See notes in Brine Tank section.
Empty and clean brine tanks	Annually	See notes in Brine Tank section.
Change particulate filter cartridges	Every 30 days or if there is a pressure drop across the device greater than 15 psi while the RO is running	See Particulate Filtration section and Change Particulate Filter Cartridge section
Change Pyrogen cartridge	Every 6 months or if there is a pressure drop across the device greater than 15 psi while the RO is running	See Pyrogen Cartridge section and Change Particulate Filter Cartridges and Pyrogen Filters section
Clean UV quartz sleeve	Every 6 months	See Ultra-Violet Irradiation section
Change UV quartz sleeve	As needed	See Ultra-Violet Irradiation section
Change UV bulb	Annually	See Ultra-Violet Irradiation section
Media inside media tanks	Better Water LLC recommends that tank media be changed every three years unless... ... otherwise specified by the medical director and/or company polices, ... by the specific thresholds determined for each individual pre-treatment component device after two verified regeneration cycles	See the section for each individual pre-treatment component device for the specific threshold
Perform chemical, microbial, and endotoxin testing on feed and product water as per AAMI requirements	Schedule established by the Medical Director	Submit samples to a qualified testing laboratory

SYSTEM MAINTENANCE, Long Term Storage or Non-Use

For long-term storage or long periods of non-use we recommend the following procedure:

1. Drain water from the system.
2. Remove any media and filters, and empty the housings/bowls.
3. Let the component devices air-dry.
4. Isolate/disconnect/bypass the Water Softener Tank and Carbon Tanks then pack the remaining portions of the system (pre-treatment, RO, and post-treatment) in preservative.
5. When ready to re-start, filter cartridge housings and media tanks should be wiped down with a mild bleach solution before installing new cartridges and new media.



part#
SUMCOO0574
BWI-3000 Preservative

SYSTEM MAINTENANCE, Adjusting the Blend Valve Temperature Setting

** Adjustments to the blend valve should be made when the RO is running, but patients are not dialyzing.*

*** 77°F is optimum operating temperature for the RO machine. Water will inherently increase in temperature by a few degrees when going through the filters; therefore the final temperature at the blend valve should be determined by achieving 77° at the RO. Keep in mind that it will take several minutes (up to 20 minutes or more) for the temperature change to reach the RO.**

FOR SERIES 5 VALVES: (for older models)

* Ensure both hot and cold water supplies are open, and the RO is running in good water quality.

1. Turn Adjustment Knob clock-wise, until it is all the way in and can no longer be turned.
2. Turn the Adjustment Knob counter-clockwise, and count the number of turns it takes for the Knob to turn all the way out, which is usually 4 ½ turns.
3. Turn the Adjustment Knob back clockwise, half the number of turns, which is usually 2 ¼ turns.
4. Remove the small Phillips screw and screw cover from the center of the Adjustment Knob.
5. Have slotted screwdriver ready to adjust the screw under the cover plate.
6. Hold the large adjusting knob stationary and adjust the slotted screw to obtain the desired temperature optimum operating temperature at the RO as discussed above.
7. Adjustments should be made in small increments, allowing time for the newly blended water to be pulled through the blend valve and for the Temperature Gauge to stabilize.
8. Once the desired temperature is obtained, re-install the center cover plate and cover screw.
9. Any further adjustments should be made with the Adjustment Knob only, in the direction indicated on the cover plate to obtain the desired temperature.

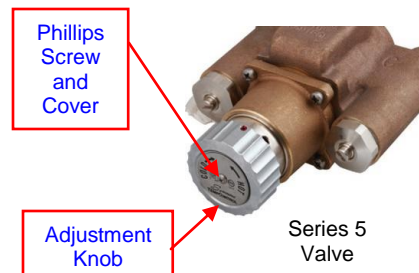

FOR SERIES 6 VALVES: (for older models)

1. Ensure both hot and cold water supplies are open, and the RO is running in good water quality.
2. Turn the Adjustment Knob clock-wise until it is all the way in and can no longer be turned. Observe the Temperature Gauge to verify that the water temperature is changing.
3. Turn the Adjustment Knob counter-clockwise, four complete turns. Observe the Temperature Gauge to verify that the water temperature is changing.
4. Repeat steps 2 and 3, two more times.
5. Turn Adjustment Knob clock-wise to adjust the water temperature to the desired setting, by verifying the Temperature Gauge reading. Allow time for the newly blended water to be pulled through the Blend Valve and for the Temperature Gauge to stabilize.
6. The final water temperature setting should be based on a verified water temperature of 77°F at the RO.
7. Any further adjustments should be done by turning the Adjustment Knob in small increments. Allow time for the newly blended water to be pulled through the Blend Valve and for the Temperature Gauge to stabilize.

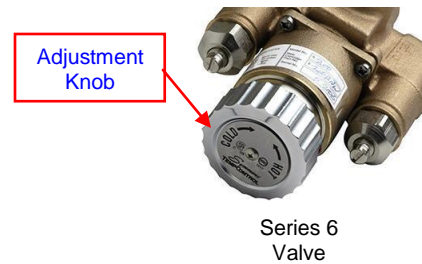
**FOR SERIES 7 VALVES:**

1. Ensure both hot and cold water supplies are open, and the RO is running in good water quality.
2. Loosen the Locking-Nut on the Adjustment Bolt, by turning it counter-clockwise until it can no longer be turned.
3. Using a wrench turn the Adjustment Bolt clock-wise until it is all the way in and can no longer be turned. Observe the Temperature Gauge to verify that the water temperature is changing.
4. Turn the Adjustment Bolt counter-clockwise, four complete turns. Observe the Temperature Gauge to verify that the water temperature is changing.
 * *CAUTION: Turning the Adjustment Bolt fully counter-clockwise will remove the Bolt from the Blend Valve. If this occurs simply replace the bolt.*
5. Repeat steps 3 and 4, two more times.
6. Turn Adjustment Bolt clock-wise to adjust the water temperature to the desired setting, by verifying the Temperature Gauge reading. Allow time for the newly blended water to be pulled through the Blend Valve and for the Temperature Gauge to stabilize.
7. The final water temperature setting should be based on a verified water temperature of 77°F at the RO.
8. Once the desired temperature has been achieved, hand-tighten the Locking Nut on the Adjustment Bolt, by turning it clockwise until it can no longer be turned to ensure the Adjustment Bolt will stay in the final position set.

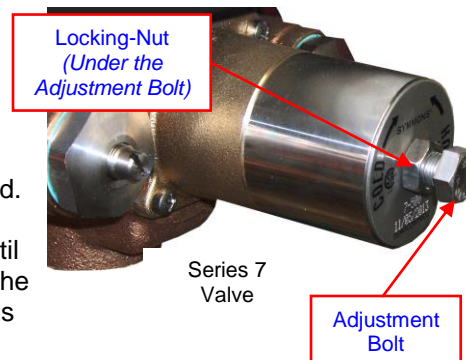

9. Any further adjustments should be done by loosening the Locking-Nut, then turning the Adjustment Bolt in small increments, and then re-tighten the Locking-Nut. Allow time for the newly blended water to be pulled through the Blend Valve and for the Temperature Gauge to stabilize.

SYSTEM MAINTENANCE, Priming the City Booster Pump and Repress Pump

WARNING

All city booster and repressurization pumps must be primed prior to initial use, or whenever air has been allowed to enter the pump. This includes the initial start-up of the pump and usually every time the pump has shutdown from a no-flow situation. Failure to complete this procedure may result in damage to the pump and may void all warranties.

To prime the pump, air must be bled from the casing of the pump from the air bleed screw.
** NOTE: The location of this screw will vary from model to model.*

1. Verify that the pump inlet valve to the pump is open and there is an ample supply of water.
2. Verify that the pump outlet valve is closed.
3. Slowly open the air bleed screw and allow air to escape until a solid stream of water is flowing from the screw. It is not necessary to completely remove the screw, as this will make it difficult to replace while the water is flowing.
4. When a solid stream of water is flowing from the air bleed screw, tighten it back down. Do not over-tighten which can damage the underlying o-ring.

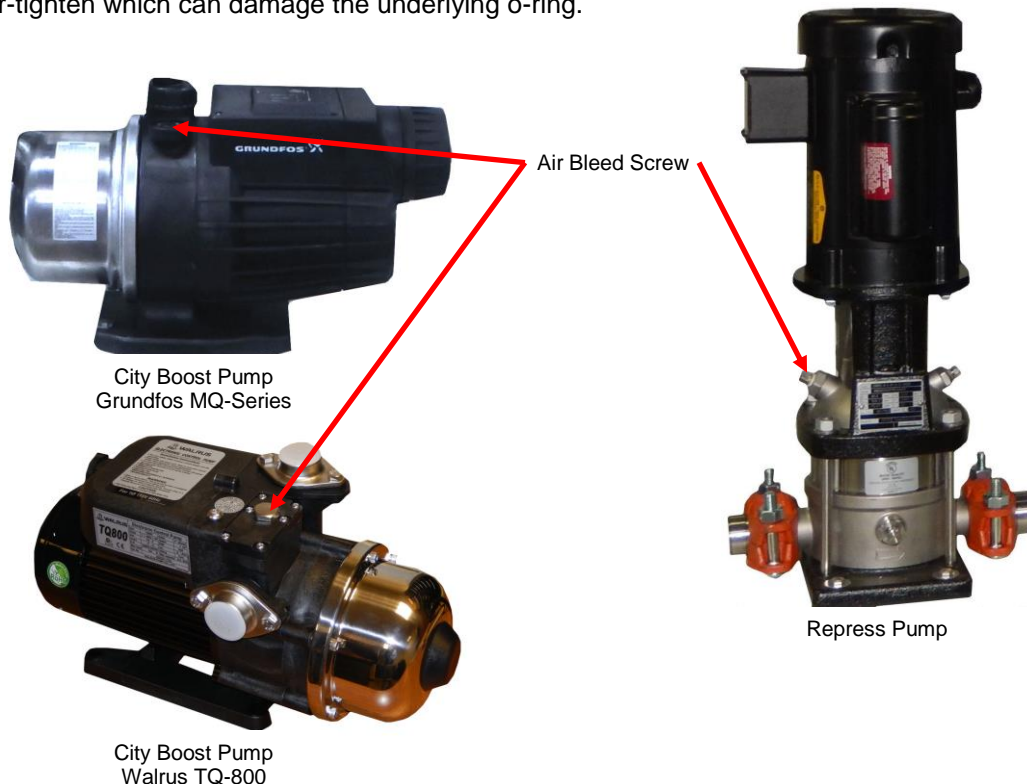

SYSTEM MAINTENANCE, Change Particulate Filter Cartridges and Pyrogen Filters

Better Water LLC, recommends changing these filters as follows:

- **5 micron Big Blue Filters:** change monthly or when the ΔP (*pressure drop*) reaches or exceeds 15 psi while the RO is running
- **.03 micron Pyrogen Filters:** change every 6 months or when the ΔP (*pressure drop*) reaches or exceeds 15 psi while the RO is running

1. Start with all valves, sample ports, vents, and drain ports closed.
2. Open the drain port on the bottom of the housing to allow the water to drain completely from the housing. Close the drain port when water flow stops.
3. Depending on the filter housing either open it, or use a filter wrench to gain access to the filter.
4. Remove the old filter(s), and wipe out the inside of the housing with a clean, damp cloth.
5. Insert the new filter(s).
6. Verify any o-rings are properly seated.
7. Depending on the filter housing, either close it, or use a filter wrench to seal the cover, without over-tightening.
8. Slowly open the inlet valve to allow water to begin filling the housing.
9. Partially open the sample port or vent to allow air to be purged from the device.
10. When water flows from the sample port or vent, signaling that the air has been purged from the device, close the sample port or vent.
11. Slowly open the outlet valve fully to allow water to flow through the device and check for leaks.
12. The filter is now on-line and ready for use.



part#
SUCAOO0551
10" Big Blue
5 Micron Filter



part#
SUMIOO0587
O-Ring for 10" Big
Blue Housing



part#
SUCAPE00575
20" .03 Ultra Filter



part#
SUMIOO0589
O-Ring for 20" Big
Blue Housing

SYSTEM MAINTENANCE, Automatic Control Valves

Set Time of Day:

1. Open the automatic control valve cover.
2. Press and hold the **Red Button** in to disengage the drive gear.
3. Turn the **Large Gear** until the actual time of day is opposite the time of day pointer.
4. Release the **Red Button** to engage the drive gear.

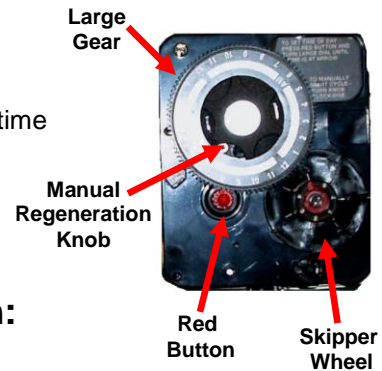

Set on Which Days to Regenerate/Backwash:

1. Open the automatic control valve cover.
2. Rotate the **Skipper Wheel** until the number is equal to the day being set, at the red pointer.
1=Monday, 2=Tuesday, 3=Wednesday, 4=Thursday, 5=Friday, 6=Saturday, 7=Sunday
3. Set the days that regeneration/backwash is to occur by sliding the tabs on the **Skipper Wheel** outward to expose trip fingers. Each tab is one day. Trip finger on the red pointer is "tonight".
4. Moving clockwise from the red pointer, extend or retract the trip fingers to obtain the desired schedule.

Initiate a Manual Regenerate/Backwash:

1. Open the automatic control valve cover.
2. Turn the **Manual Regeneration Knob (black-center)** clockwise.
3. This knob will make one revolution in approximately three hours.
4. Even though it takes three hours for this knob to complete one revolution, the regeneration/backwash cycle of your unit might be set for only one half of this time.
5. In any event, conditioned water may be drawn after rinse water stops flowing from the drain line.

Changing Regenerate/Backwash Program Cycles:

WARNING:

There can be dire consequences to the quality of the water produced by the pre-treatment system which can affect the RO and ultimately any patient undergoing hemodialysis treatment if the backwash and regeneration cycles are programmed incorrectly.

NOTE

The backwash and regeneration cycles are critical procedures in the pretreatment process. There is a very balanced, structured, and programmed relationship between the different pre-treatment component devices and the RO. Because of these, great care must be taken when making any changes to the backwash and regeneration cycle programs that have been setup by the manufacturer or authorized dealer. Before considering or attempting to make any changes to these cycles by changing the pin and hole settings on the regeneration cycle program wheel, technical support should be consulted to advise and support any such changes.

The Fleck valve time settings for both filters and softeners have been provided for reference below:

TIME SETTINGS FOR FILTERS (FLECK VALVES)											
TANK SIZE	vol. of carbon	vol. of gravel	valve	BACKWASH TIME		SLOW RINSE TIME		FAST RINSE TIME		To put back into service	
				MINUTES	PINS	MINUTES	HOLES	MINUTES	PINS	HOLES	PINS
12 X 52	2	50lbs	Fleck 2750	12	6	4	2	6	3	2	2
14 X 65	3	50lbs	Fleck 2750	16	8	4	2	6	3	2	2
16 X 65	4	100lbs	Fleck 2850	20	10	4	2	8	4	2	2
20 X 62	4,5,6	100lbs	Fleck 2850	20	10	4	2	10	5	2	2
24 X 71	7,8,9,10,11	150lbs	Fleck 2850	20	10	4	2	12	6	2	2
30 X 72	12,13	250lbs	Fleck 3150	22	11	4	2	16	8	2	2

TIME SETTINGS FOR SOFTENERS (FLECK VALVES)													
TANK SIZE	VOL. OF RESIN	VOL OF GRAVEL	VALVE	REGENERATE		SLOW RINSE		FAST RINSE		BRINE RE-FILL		PINS TO BUT BACK INTO SERVICE POSITION	BRINE TANK SIZE
				TIME	PINS	TIME	HOLES	TIME	PINS	TIME	HOLES		
12x52	2 CF	50 LBS	FLECK 2750	10 MIN	5	46 MIN	23	10 MIN	5	16 MIN	8	2	18 x 40
14x65	3 CF	50 LBS	2750 or 2850	10 MIN	5	46 MIN	23	10 MIN	5	16 MIN	8	2	18 x 40
16x65	4 CF	50 LBS	FLECK 2850	10 MIN	5	62 MIN	31	10 MIN	5	18 MIN	9	2	18 x 40
20x62	4-7 CF	100 LBS	FLECK 2850	10 MIN	5	70 MIN	35	10 MIN	5	18 MIN	9	2	24 x 50
24x71	7-10 CF	150 LBS	FLECK 2850	10 MIN	5	70 MIN	35	10 MIN	5	18 MIN	9	2	24 x 50
30x72	15 CF		FLECK 3150	10 MIN	5	88 MIN	44	10 MIN	5	16 MIN	8	2	24 x 50

Replacing Seals and Spacers:

The seals and spacers in the valve should be changed every 3 to 5 years. This may have to be done sooner if there is a malfunction of the valves. This procedure applies to Fleck head models (2750, 2850, 2900, and 3150)

* You will need the following tools:

- Appropriate socket
- Seal hook
- Puller
- Spacer
- Spacers/Seals Kit

See Related Consumable and Replacement Parts section for part numbers specific to the Fleck valve

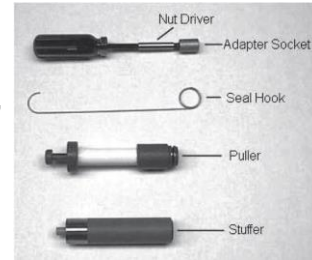

1. Turn off water supply to valve. Next cycle the valve to backwash position, then to service. Now remove electrical plug from outlet.

2. Remove control box cover.

3. Disconnect the brine line from the injector housing to the brine valve (if your unit has timed brine tank fill).

4. Remove the two cap-screws that hold the back plate to the valve.

5. Grasp the back plate on both sides and slowly pull end plug and piston assembly out of the valve body and lay aside. (see figure 1)

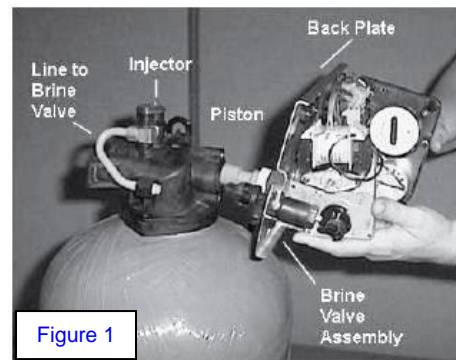

6. Remove the seal first using the wire hook with the finger loop. (see figure 2)

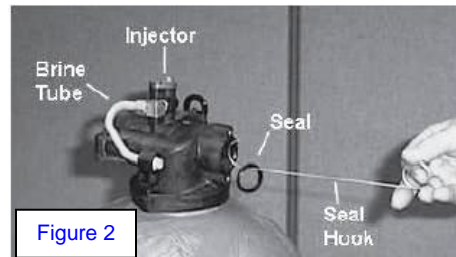

7. The puller tool (use only for removing the spacers) has three retractable pins, retained by a rubber ring, at one end. They are retracted or pushed out by pulling or pushing the center button the opposite end.

8. Insert the pin end of the spacer tool into the valve body with the pins retracted (button pulled back). Push the tool tight against the spacer and push the button in. When the button is pushed in, the pins are pushed out to engage the ¼ diameter holes in the spacer. Remove the tool from the valve body. The spacer will be on the end. Pull the center button back, the pins will be retracted and the spacer can be removed from the spacer tool. (see figure 3)

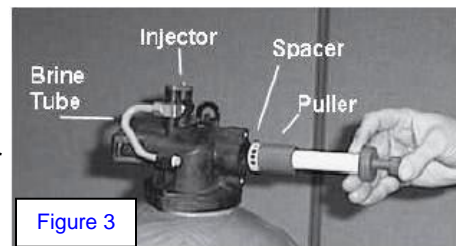

9. Alternately remove the remaining seals and spacers in accordance with steps 6 and 8.

10. The last or end spacer does not have any holes for the pins of the spacer tool to engage, therefore if the end spacer does not come out on the first try, try again using the wire hook with the finger loop.

(continued)

11. To replace the seals, spacers, and end ring, use the stuffer tool with the brass sleeve on one end. This is a double-purpose tool. The male end acts as a pilot to hold the spacers as they are pushed into the valve body and the brass female end is used to insert the seals into the valve body.

12. To re-stuff a valve body, first take the end ring (the plastic or brass ring without holes), then with your thumb press the button on the brass sleeve end. The large diameter inner portion is now exposed. Place the end ring on this pilot with the lip on the end ring facing the tool. Push the tool into the valve body bore until it bottoms. While the tool is in the valve body, take a seal and press it into the inside diameter of the exposed brass female end. (see figure 4)

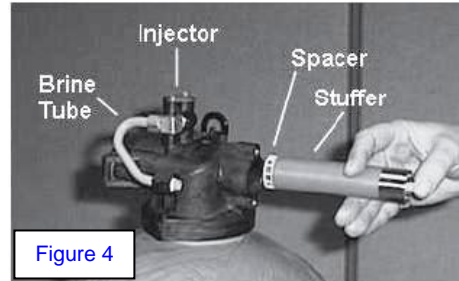

13. Remove the tool, turn it end for end and insert it into the valve body bore. While holding the large diameter of the tool, slide it all the way into the valve body bore until it bottoms. Then push the center button to push the seal of the tool and leave it in place in the valve body.

14. Remove the tool from the valve body and push the center on the brass female end to expose the pilot on the opposite end. Place a spacer on this end and insert the spacer and tool into the valve. Continue until all spacers and seals are in place.

15. Reattach back plate, reconnect brine line (if applicable), re-attach the control box cover, reconnect to power outlet, and turn water supply back on to valve.

16. Verify operation by doing a manual regeneration or backwash, then perform residual testing.

SERVICE HELP: MediPac, Post-Treatment End

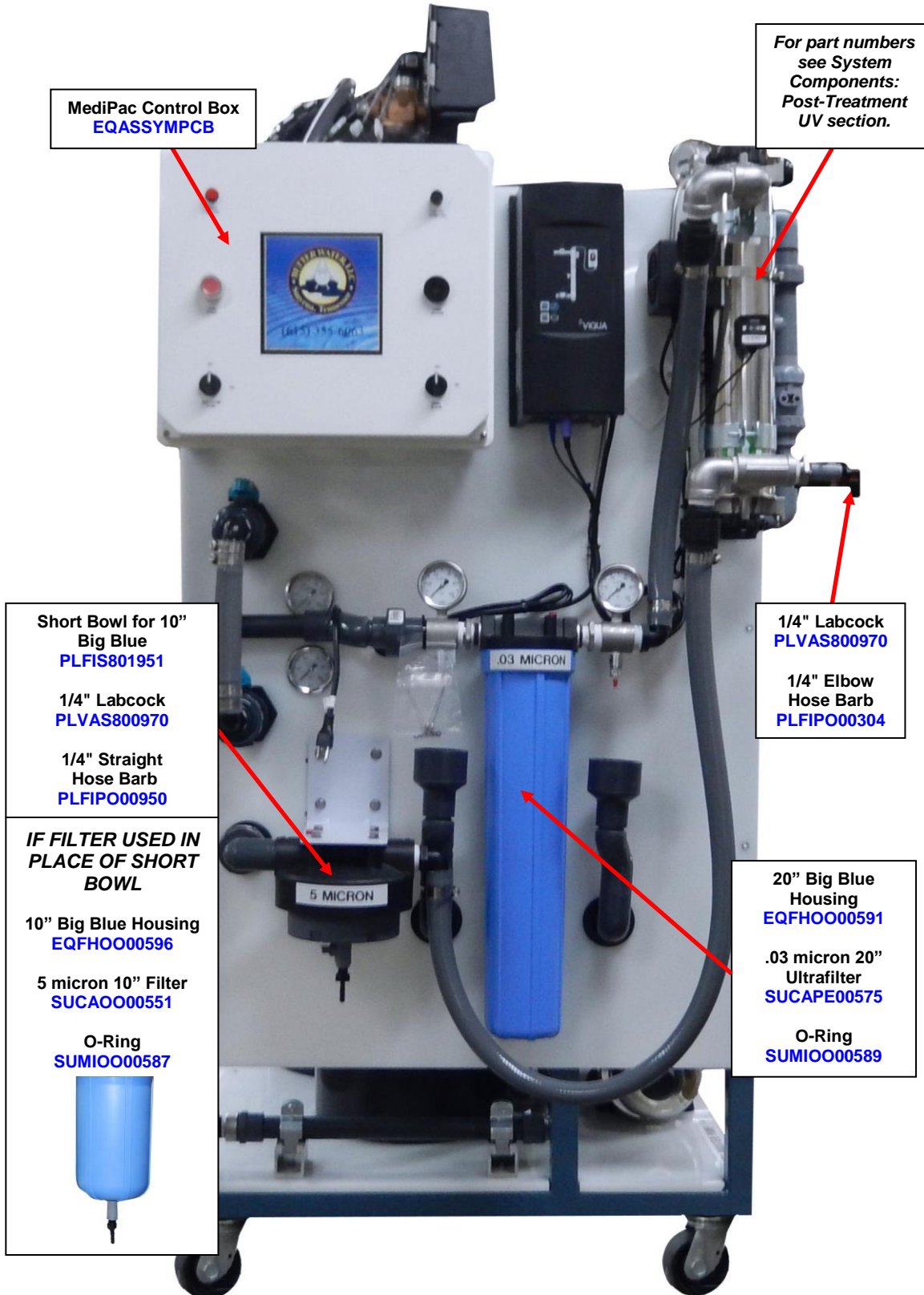

SERVICE HELP: MediPac, 1232 RO End

* See 1232 Operator Manual for additional information

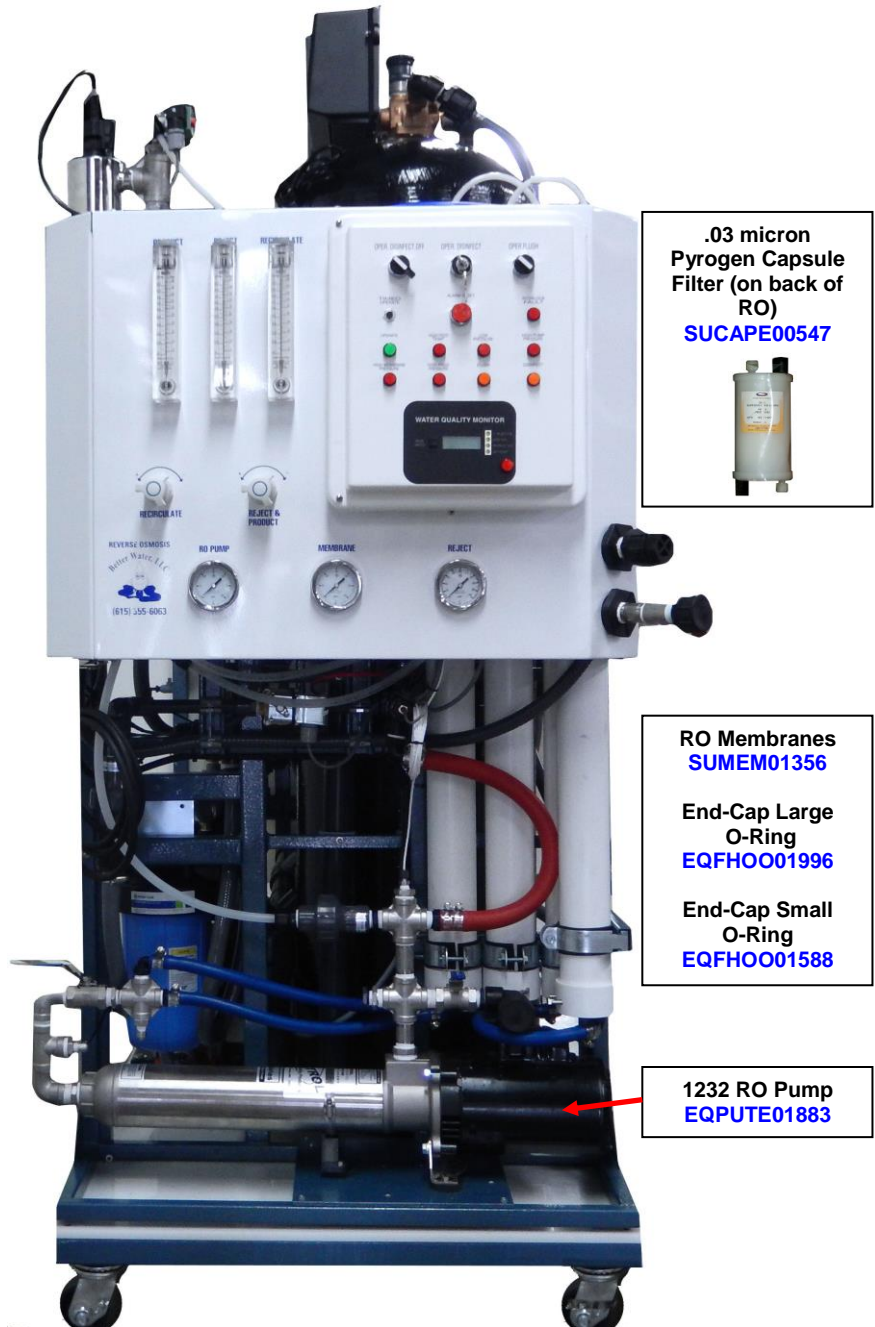

SERVICE HELP: MediPac, Front-Side

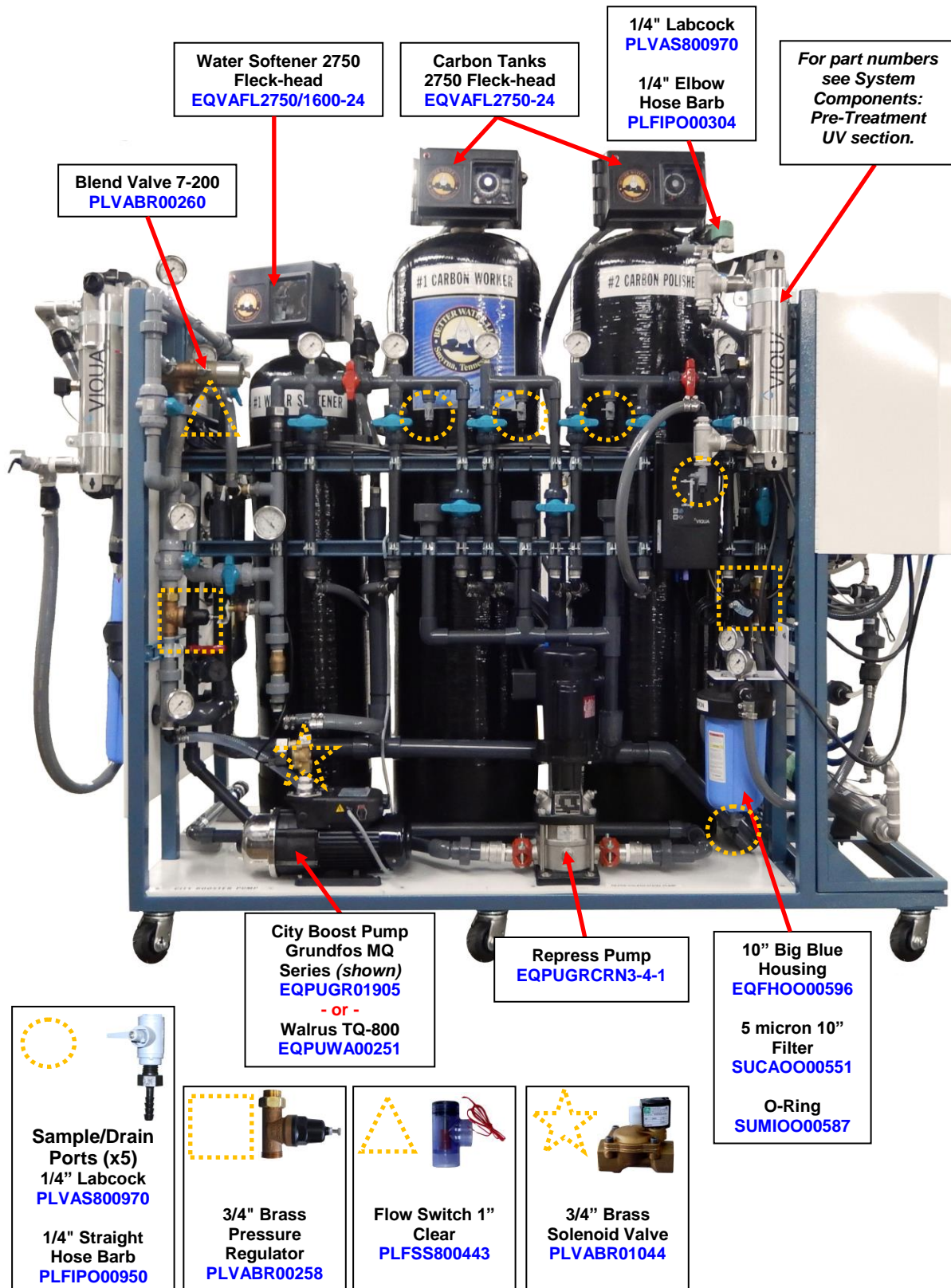

Water Softener 2750 Fleck-head
EQVAFL2750/1600-24

Carbon Tanks 2750 Fleck-head
EQVAFL2750-24

1/4" Labcock PLVAS800970
1/4" Elbow Hose Barb PLFIPO00304

For part numbers see System Components: Pre-Treatment UV section.

Blend Valve 7-200 PLVABR00260

City Boost Pump Grundfos MQ Series (shown) EQPUGR01905
- or -
Walrus TQ-800 EQPUWA00251

Repress Pump EQPUGRCRN3-4-1

10" Big Blue Housing EQFHOO00596
5 micron 10" Filter SUCAOO00551
O-Ring SUMIOO00587

Sample/Drain Ports (x5) 1/4" Labcock PLVAS800970
1/4" Straight Hose Barb PLFIPO00950

3/4" Brass Pressure Regulator PLVABR00258

Flow Switch 1" Clear PLFSS800443

3/4" Brass Solenoid Valve PLVABR01044

SERVICE HELP: MediPac Control Box (front view)

Part# **EQASSYMPCB**

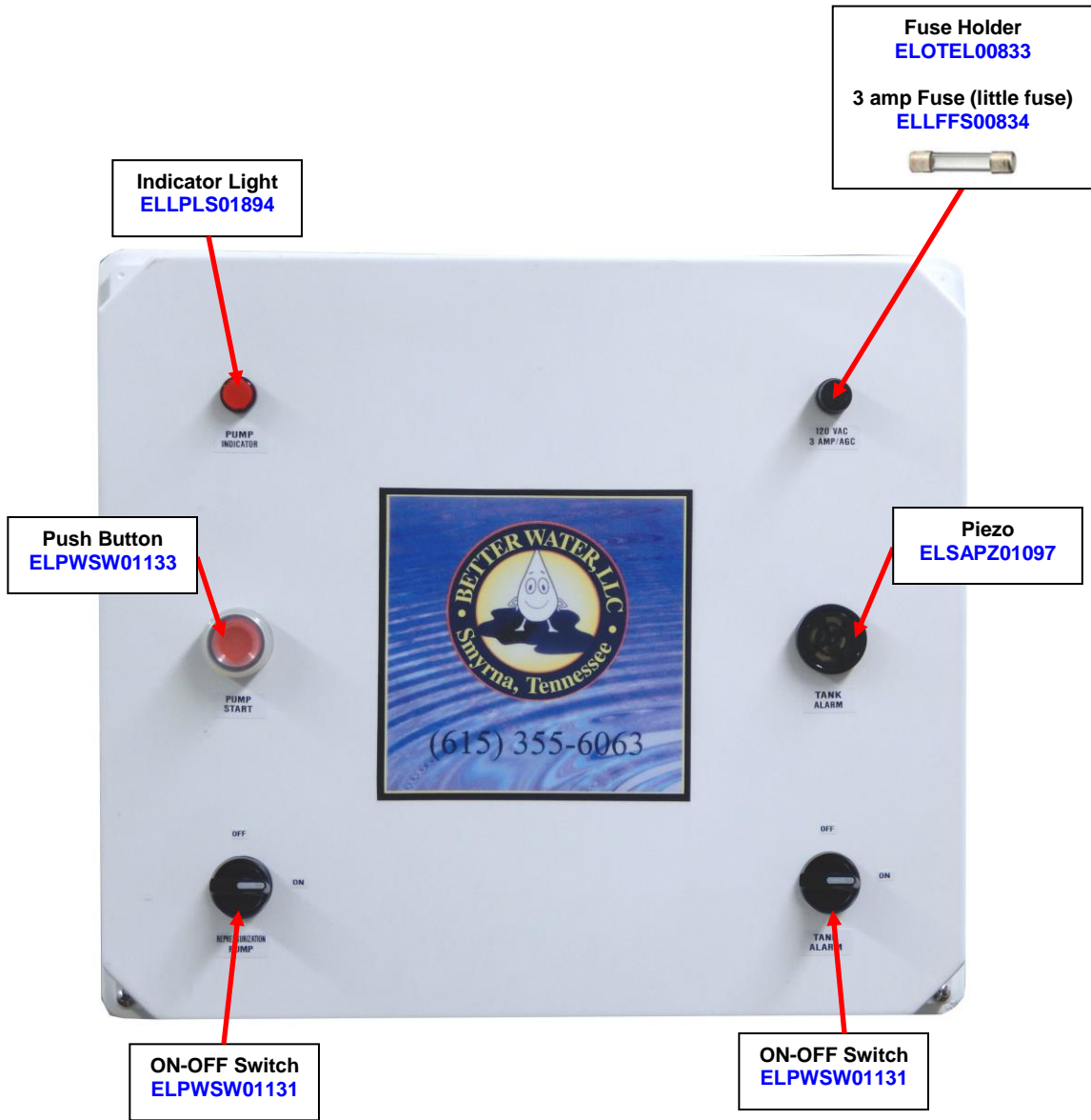

SERVICE HELP: MediPac Control Box (inside lid view)

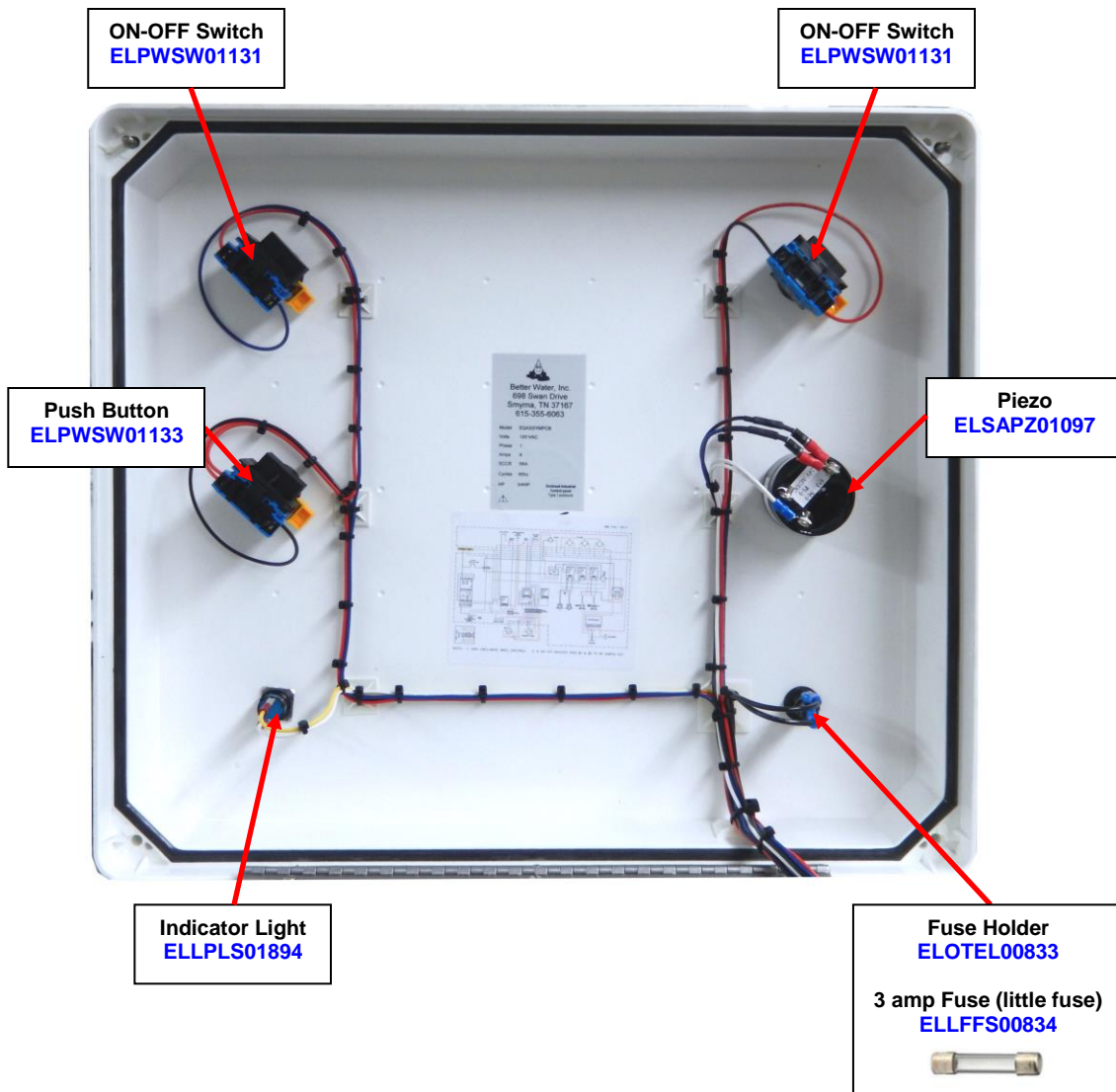

SERVICE HELP: MediPac Control Box (inside view)

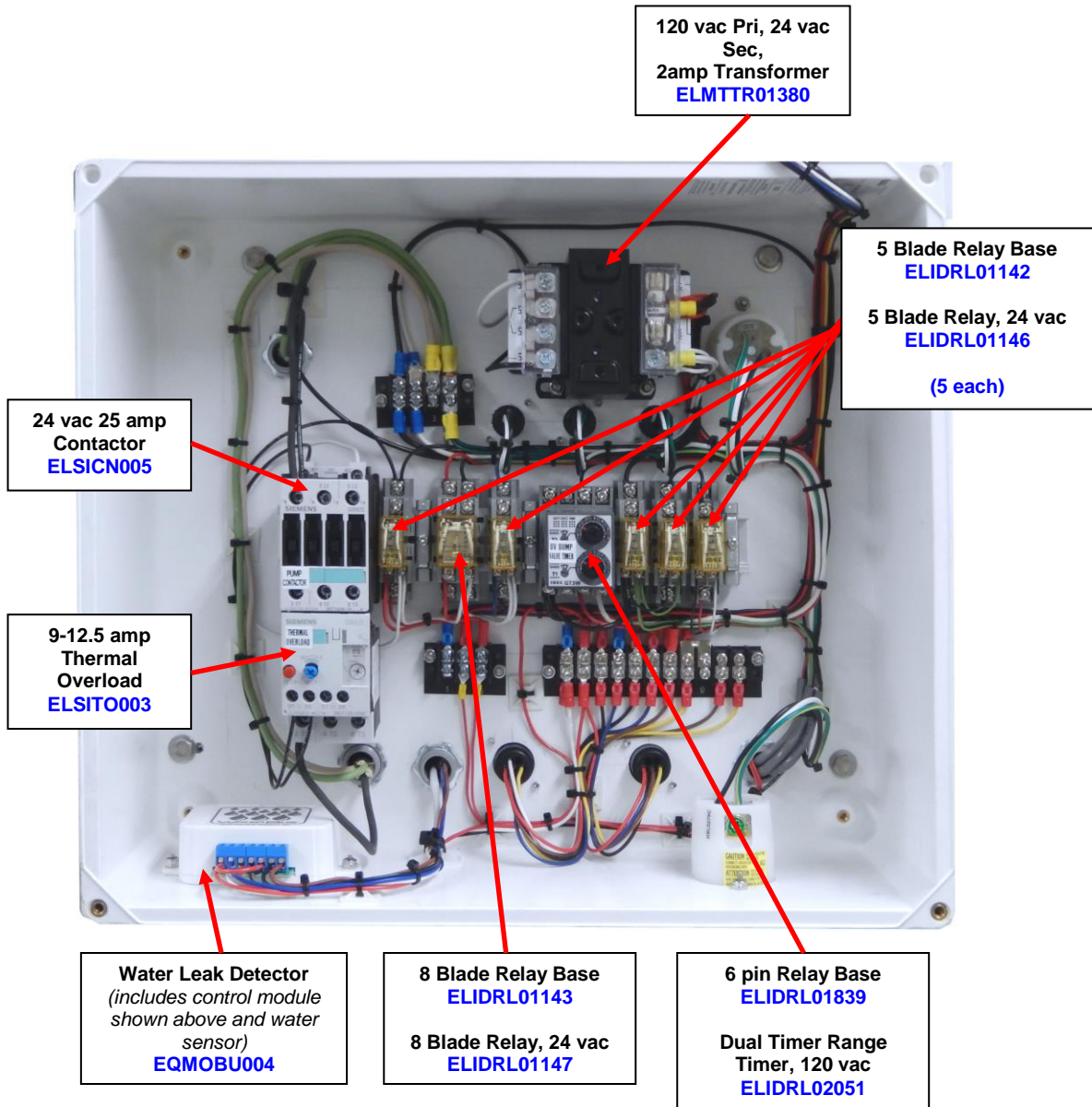



RELATED CONSUMABLE and REPLACEMENT ITEMS

DESCRIPTION	PART#	PICTURE
10" Big Blue, 5 micron Filter - O-ring SUMIOO00587	SUCAOO00551	
.02 micron Tank Vent Filter	SUCAOO00557	
.03 micron Pyrogen Capsule Filter - 1232 RO filter	SUCAPE00547	
20" Ultra Filter, .03 Micron - O-ring SUMIOO00589	SUCAPE00575	
1232 RO Membrane, 2.5" x 40" - Large end-cap o-ring EQFHOO01996 - Small end-cap o-ring EQFHOO01588	SUMEM01356	
UV Bulb, Pre-Treatment - UV SPV-410 - UV Pro-Max 10	SUUVOO02024 SUUVOO02023	
UV Quartz Sleeve, Pre-Treatment - UV SPV-410 - UV Pro-Max 10	SUUVOO02025 SUUVOO02022	
UV Bulb, Post-Treatment - UV SPV-600 - UV Pro-Max 10	SUUVOO02026 SUUVOO02023	
UV Quartz Sleeve, Post-Treatment - UV SPV-600 - UV Pro-Max 10	SUUVOO02027 SUUVOO02022	







Pictures do not reflect the size of the item in relation to the other pictures

RELATED CONSUMABLE and REPLACEMENT ITEMS

DESCRIPTION	PART#	PICTURE
Seal and Spacer Rebuild Kit for Fleck Valves - For Fleck valve 2750 - For Fleck valve 2850 - For Fleck valve 3150 <i>* Kit contains all the necessary spacers and o-rings for rebuilding the valve. Contents will vary from picture based on valve ordering for</i>	EQVAFL2750REBUILD EQVAFL2850REBUILD EQVAFL3150REBUILD	
Fleck Valve Puller Tool - For Fleck valve 2750 - For Fleck valve 2850 - For Fleck valve 3150	EQVAFL12682 EQVAFL13061 EQVAFL17623	
Fleck Valve Stuffer Tool - For Fleck valve 2750 - For Fleck valve 2850 - For Fleck valve 3150	EQVAFL11098 EQVAFL12683 EQVAFL16516	





Pictures do not reflect the size of the item in relation to the other pictures

RELATED DISINFECTANTS & CLEANERS

DESCRIPTION	PART#	PICTURE
BWI-2000 Alkaline Cleaner, low pH	SUMCOO00571	
BWI-1000 Acid Cleaner, high pH	SUMCOO00572	
BWI-3000 Membrane Preservative - Memstor preservative	SUMCOO00574	
Minnicare, Disinfectant	SUMCOO00575	
Minnicare Disinfect Residual Test Strips, 100 pk	SUMCOO00576	
Minnicare 1% Test Strips, 100 pk	SUMCOO00577	

Pictures do not reflect the size of the item in relation to the other pictures

RELATED CONSUMABLE MEDIA

DESCRIPTION	PART#	PICTURE
Carbon Tank Media - 1 cubic ft bag	EQMEOO00467	
Softener Resin - 1 cubic foot box, Purolite C100X10-S	EQMEOO01675	
Media Gravel - 50 lb bag	EQMEOO01774	
Brine Tank Salt - Cargil SOD Chloride Pellet, 50 lb bag	SUMI01659	

Pictures do not reflect the size of the item in relation to the other pictures

LIMITED WARRANTY TERMS and CONDITIONS

- a. This limited warranty is given only to the original buyer and covers the equipment delivered with this limited warranty.
- b. The buyer shall be barred from any recovery on this limited warranty or otherwise for damages due in whole or in part to...
 - ... unreasonable use
 - ... improper operation
 - ... use beyond normal fashion
 - ... failure to follow instructions
 - ... failure to maintain the product in good condition and repair
 - ... or the like.
- c. If the buyer discovers or should have discovered a defect in which it is reasonable to conclude that damage, either personal, property, or economic, may result, the buyer's continued use of the product shall constitute any assumption of risk by the buyer and a bar to any recovery for breach of this limited warranty or otherwise.
- d. No oral or written representation, information, or advice given by Better Water LLC or any of its representatives shall create a warranty or in any way increase the scope of this express limited warranty and shall not form a part of the basis for bargain.

WHAT IS WARRANTED AND FOR HOW LONG?

- a. All equipment, excluding ion exchange and filtration media and cartridges, are warranted to be free from factory defects in materials, and workmanship under normal use for a period of one (1) year from the date of shipment.
- b. It is a condition precedent to recovery on this limited warranty that the buyer strictly comply with all operating and maintenance guidelines established by Better Water LLC and that the serial number (*if applicable*) is intact and legible on the equipment.
- c. It is a condition precedent to recovery on this limited warranty for damage to the external finish of the equipment that the buyer notifies Better Water LLC at the time of the installation that the finish is damaged.

WHAT IS REMEDY FOR BREACH OF THIS LIMITED WARRANTY or NEGLIGENCE BY BETTER WATER LLC

- a. Buyer's sole and exclusive remedy for any breach of this limited warranty or negligence by Better Water LLC shall be repair or replacement of the defective part, at the option of Better Water LLC, provided such defective part is returned to Better Water LLC for inspection.
- b. Better Water LLC shall not be obligated to supply an exact replacement of the defective part and reserves the right to substitute new and improved parts.
- c. Better Water LLC shall provide at no cost to buyer, labor to remove and/or replace defective parts covered by this limited warranty for a period of ninety (90) days from the date of installation by Better Water LLC of the equipment.
- d. After such ninety (90) day period, buyer shall be responsible for any labor or service charge for the removal and/or replacement of any defective parts.
- e. Buyer shall be responsible for all travel expenses and freight charges at all times.
- f. Better Water LLC shall have no obligation to repair or replace any defective part if buyer fails to follow the procedure set forth in "HOW TO OBTAIN A REPLACEMENT PART UNDER LIMITED WARRANTY".

IN NO EVENT SHALL THIS LIMITED WARRANTY BE CONSTRUED TO COVER, NOR SHALL BETTER WATER LLC BE LIABLE TO BUYER AS ANY OTHER PERSON FOR, ANY CONSEQUENTIAL, INCIDENTAL, ECONOMIC, DIRECT, INDIRECT, GENERAL OR SPECIAL DAMAGES, WHICH ARE HEREBY EXPRESSLY DISCLAIMED.

HOW TO OBTAIN A REPLACEMENT PART UNDER LIMITED WARRANTY

- a. Buyer should contact the Customer Service or Technical Support Departments and request a Return Goods Authorization.

b. Described part(s) will be sent with a purchase order.

c. The returned part(s) will be returned to the factory for limited warranty consideration. If part(s) are not covered under the limited warranty, part(s) will be considered billable against the purchase order supplied.

WHAT IS NOT COVERED BY THIS LIMITED WARRANTY:

By way of example and not limitation, this limited warranty does not cover:

- Damage to or replacement of any ion exchange resin or filter media
- Labor or service charges for the removal and/or replacement of any defective parts after the ninety (90) day period from the date of installation or sale by Better Water LLC
- Freight charges and travel expenses
- Damage from inadequate or defective wiring, improper voltage, improper connections or electrical service, inadequate or defective plumbing, water supply, or water pressure, or in violation of applicable building, plumbing or electrical codes, laws, ordinances or regulations.
- Damage from improper installation or operation, including but not limited to, abuse, accident, neglect, improper maintenance, freezing and fires, or abnormal use.
- Damage caused by contaminants in Buyer's water supply, including hardness, chlorine, chloramines, sulfur, bacterial iron, tannin, algae, oil, organic matter or other unusual substances, if special equipment has not been installed by Better Water LLC to remove such contaminants
- Damage to or caused by filters/membranes or other replacement parts not purchased from Better Water LLC or damage caused by modification, alteration, repair or service of the equipment or any of its parts by anyone other than Better Water LLC or its expressly authorized representatives.

APPENDIX A: Sample Quality Assurance Checklist

WATER TREATMENT SYSTEM QUALITY ASSURANCE CHECKLIST (example)							
ITEMS TO BE CHECKED	MON	TUE	WED	THU	FRI	SAT	SUN
DATE							
Pre-Treatment General							
Incoming Cold Water Pressure, psi							
Incoming Hot Water Pressure, psi							
Post Blend Valve Pressure, psi							
Water Temperature Post-Blend Valve							
Pre-City Booster Pump Pressure, psi							
Post-City Booster Pump Pressure, psi							
Pre-Treatment, Water Softener							
Pre-Softener Pressure, psi							
Post-Softener Pressure, psi							
ΔP Pressure, psi (<15 psi)							
Pre-Softener Hardness, grains							
Post-Softener Hardness, grains							
Salt in Brine Tank? (<50%)							
Pre-Treatment, Carbon Tank (Worker)							
Pre-Tank Pressure, psi							
Post-Tank Pressure, psi							
ΔP Pressure, psi (<15 psi)							
Post-Tank Total Chlorine, ppm							
Post Tank Free Chlorine, ppm							
Pre-Treatment, Carbon Tank (Polisher)							
Pre-Tank Pressure, psi							
Post-Tank Pressure, psi							
ΔP Pressure, psi (<15 psi)							
Post-Tank Total Chlorine, ppm							
Post Tank Free Chlorine, ppm							
Pre-Treatment, Big Blue Filter							
Pre-Filter Pressure, psi							
Post-Filter Pressure, psi							
ΔP Pressure, psi (<15 psi)							
Pre-Treatment, U.V. Light (pre-RO)							
Pre-U.V. Light Pressure, psi							
Post-U.V. Light Pressure, psi							
U.V. Light On?							

APPENDIX A: Sample Quality Assurance Checklist

WATER TREATMENT SYSTEM QUALITY ASSURANCE CHECKLIST (example)							
ITEMS TO BE CHECKED	MON	TUE	WED	THU	FRI	SAT	SUN
RO, Switch Positions							
Check Normal Operation TANK							
Check Normal Operation DIRECT							
RO Flushes Correctly							
RO goes into Disinfect							
RO, Lights and Alarms							
Operate Light ON?							
High Feed Temp. OFF?							
Low Pressure Shuts OFF at psi?							
High Product Pressure Shuts Off at psi?							
Poor Water Quality Monitor functions properly?							
Interlock Fault Light Off?							
RO, Flow-Meters							
Product Flow in gpm							
Reject Flow in gpm							
Recirculation Flow in gpm							
RO, Water Quality Meter							
Feed Water TDS in ppm							
Product Water TDS in ppm							
Rejection Rate (>90%)							
Poor Water Quality Set-Point							
RO, Pressure Gauges							
Membrane Pressure, psi							
Reject Pressure, psi							
Product Pressure, psi							
Post-Treatment, Big Blue Filter							
Pre-Filter Pressure, psi							
Post-Filter Pressure, psi							
ΔP Pressure, psi (<15)							
Post-Treatment, .03 Filter							
Pre-Filter Pressure, psi							
Post-Filter Pressure, psi							
ΔP Pressure, psi (<15)							
Post-Treatment, U.V. Light							
Pre-U.V. Light Pressure, psi							

APPENDIX A: Sample Quality Assurance Checklist page 3

WATER TREATMENT SYSTEM QUALITY ASSURANCE CHECKLIST (example)							
ITEMS TO BE CHECKED	MON	TUE	WED	THU	FRI	SAT	SUN
Post-U.V. Light Pressure, psi							
U.V. Light On?							
Post-Treatment, Storage Tank							
Water Level above second sensor?							
Tank Vent Filter, date last changed							
Tank Vent Filter, date of next change							
DI Tanks							
Pre-Tank Pressure, psi							
Post-Tank Pressure, psi							
ΔP Pressure, psi (<15 psi)							
Technician's Initials							

APPENDIX B: BLEACH USE in the POST-TREATMENT COMPONENTS (TANK-FEED SYSTEMS ONLY)

The use of typical household bleach (5.25%) is common for use in disinfecting water treatment systems for hemodialysis. Bleach is a cost effective disinfectant and generally produces satisfactory results. Varying concentrations of Sodium Hypochlorite (bleach) are used among dialysis facilities for disinfection.

- a. 5.25% household bleach is 50,000 ppm Sodium Hypochlorite
- b. 6% household bleach is 60,000 ppm Sodium Hypochlorite

Better Water LLC recommends using IRON FREE bleach. Care should be taken to select iron free bleach because many discount or generic brands will have high iron content. Iron will be harmful to the equipment and shorten its lifespan.

*** WARNING: DO NOT USE "SPASH-LESS" BLEACH. The content of "splash-less" bleach may damage the equipment, and will create foam.**

SOLUTION

- a. 500 ppm solution of sodium hypochlorite (*bleach*)

This is 1 gallon (128 ounces) of bleach per 100 gallons of water or a **1:100 dilution**

5.25% = 500 ppm dilution Water Gallons x 1.28 = ounces of bleach 5.25%

6% = 600 ppm dilution Water Gallons x 0.96 = ounces of bleach 6%

*** Total water gallons should include gallons in the tank as well as the loop.**

- b. Recommended dwell time is **30-60 minutes**

*** See below for other bleach dilution ratios and pipe volume calculations, and 3 feet per second flow velocity rates if needed.**

BLEACH DISINFECTING DILUTIONS

- a. 5.25% household bleach is 50,000 ppm Sodium Hypochlorite

- b. 6% household bleach is 60,000 ppm Sodium Hypochlorite

1:50 Dilution

5.25% = 1000 ppm

6% = 1200 ppm

Tank Gallons x 2.56 = ounces of bleach 5.25%

Tank Gallons x 1.92 = ounces of bleach 6%

1:100 Dilution

5.25% = 500 ppm

6% = 600 ppm

Tank Gallons x 1.28 = ounces of bleach 5.25%

Tank Gallons x 0.96 = ounces of bleach 6%

1:500 Dilution

5.25% = 100 ppm

6% = 120 ppm

Tank Gallons x 0.64 = ounces of bleach 5.25%

Tank Gallons x 0.48 = ounces of bleach 6%

1:1000 Dilution

5.25% = 50 ppm

6% = 60 ppm

Tank Gallons x 0.128 = ounces of bleach 5.25%

Tank Gallons x 0.096 = ounces of bleach 6%

WARNING

Also, DO NOT use "Sodium Hypochlorite" (bleach) based products as these will damage the RO's membranes.

APPENDIX C: CALCULATIONS & CONVERSIONS

CONVERSION FORMULAS

OUNCES to MILLILITERS

Formula: **Fluid Ounces x 29.6 = Milliliters**

Example: 128 oz x 29.6 = 3790 milliliters

MILLILITERS to OUNCES

Formula: **Milliliters / 29.6 = Ounces**

Example: 750 ml / 29.6 = 25.34 ounces

GALLONS to OUNCES

Formula: **Gallon * 128 = Ounces**

*Example: 1 gal * 128 = 128 ounces*

OUNCES to GALLONS

Formula: **Ounces / 128 = Gallons**

Example: 128 ounces / 128 = 1 Gallon

CALCULATION for AREA of PIPE VOLUME

To calculate the cross sectional area of pipe, use the following formula: $\text{Area} = \pi \times r^2$

- $\pi = 3.14$

- r = radius (*which is $\frac{1}{2}$ the diameter*)

The following calculation uses a 1" diameter pipe as an example:

Calculate the cross sectional area of the pipe using the formula above:

- | | |
|---|---|
| 1. divide the diameter by 2 to get the radius in inches | $1" \text{ diameter} / 2 = \mathbf{0.5 \text{ inches}}$ |
| 2. divide the radius by 12 to convert from inches to feet | $0.5 / 12 = \mathbf{0.0417 \text{ feet}}$ |
| 3. square the radius | $0.0417^2 = \mathbf{.00174 \text{ sq ft}}$ |
| 4. Multiply by pi | $0.00174 \times 3.14 = \mathbf{.00546 \text{ sq ft}}$ |

Answer: the area of a 1" diameter pipe is 0.00546 ft²

3 FEET per SECOND FLOW VELOCITY RATES

Nominal Loop Pipe Inner Diameter

3/4" Teflon id	=	0.60in.
3/4" schedule 80 pvc id	=	0.74in
1" Teflon id	=	0.88in
1" schedule 80 id	=	0.96in
1 1/2" schedule 80 id	=	1.48 in
3/4" (25mm) polypropylene id	=	0.80in
1" (32mm) polypropylene id	=	1.03in
1 1/2" (50mm) polypropylene id	=	1.61 in

Nominal Flow Rates at 3 Feet per Second

3/4" Teflon	=	2.64 gpm @ 3ft/sec (Nominal)
3/4" schedule 80 pvc	=	4.02 gpm @ 3ft/sec (Nominal)
1" Teflon	=	5.69 gpm @ 3ft/sec (Nominal)
1" schedule 80	=	6.77 gpm @ 3ft/sec (Nominal)
1 1/2" schedule 80	=	16.1 gpm @ 3ft/sec (Nominal)
3/4" (25mm) polypropylene	=	4.70 gpm @ 3ft/sec (Nominal)
1" (32mm) polypropylene	=	7.79 gpm @ 3ft/sec (Nominal)
1 1/2" (50mm) polypropylene	=	19.0 gpm @ 3ft/sec (Nominal)

- a. All 3ft/sec flow rates at the loop return flow meter are calculated for the loop inner diameter only.
 - b. The above flow rates should be set with all dialysis machines running.
 - c. If bicarb or acid makeup water is required, both should have the proper flow controls to maintain flow velocity.
-

