

Better Water LLC

Dual Tank Bicarb-Short Profile Central Mix and Delivery Operator Manual



rev. Jun 2017

Better Water LLC. All rights reserved.

The content of this manual is the intellectual property of Better Water LLC. It is furnished for the express use by Better Water LLC, their customers and dealers, for informational use only for operation, service, and internal training. No part of this manual may be reproduced for distribution, sale, or any intent other than previously described without the written permission of Better Water LLC. This manual is subject to change without notice. Better Water LLC assumes no responsibility or liability for any error or inaccuracies that may appear in this documentation.

Adobe and Acrobat are registered trademarks of Adobe Systems, Inc.

TABLE OF CONTENTS

Our Company	01
- Contact Us	01
- Technical Phone Support	01
- Technical Support Info Online	01
- Specific Contacts	02
Introduction	02
Warnings & Cautions	03
Models	04
- Important Information for Support	04
Product Description	05
- Dual Tank Unit with Mixers and Pumps	06
- Control Box	07
- Loop Header	07
- Bicarb Remote Alarm Box (optional)	08
General Requirements & Specifications	08
Operation	09
- Bicarb Unit Valve Legend & Descriptions	10
- Familiarization with Control Box	13
- Silencing an Alarm	14
- After-Hours Circulation Drain	15
- Filling Tank#1	15
- Filling Tank#2	16
- Mixing Bicarbonate Solution in Tank#1 or Tank#2	16
- Priming the Loop	17
- Setup for One-Tank Operation from Tank#1	17
- Setup for One-Tank Operation from Tank#2	18
- Setup for Simultaneous Two-Tank Operation	18
- Starting Pump for Distribution to the Loop	19
- End of Treatment Day Rinse and Drain	19
- After-Hours Circulation	21
General Cleaning and Disinfecting Information	22
- Disinfecting Procedure	23
- Cleaning Procedure	29
System Maintenance:	
- General	35
- Calibrating the Bicarb Unit Regulator for Floor-Valve-Boxes and Panels	35
Long Term Storage	37
Related Replacement Parts	38
Trouble-Shooting Guide	42
Limited Warranty Terms and Conditions	44

Appendix A, Calculations & Conversions 46

- Bleach Disinfecting Dilutions 46
- Conversion Formulas 46
- Calculation for Area of Pipe Volume 47
- 3 Feet per Second Flow Velocity Rates 47

Appendix B, Pre-Ship Test Data 49

Visit our website to see our complete product line of water purification products!

www.betterwater.com



Our Company

Better Water LLC is a leading integrated manufacturer of water treatment equipment and components for the industrial, commercial and institutional markets.



Located in Smyrna, Tennessee, Better Water LLC continues its history of manufacturing and distribution of equipment specifically designed for the renal dialysis market.

Founded in 1971, Better Water LLC has built a reputation for solving our customers' toughest problems with high quality products and unmatched service.

Contact Us

Better Water LLC
698 Swan Dr
Smyrna, TN 37167

Phone (615) 355-6063
Fax (615) 355-6065

Technical Support:
Phone (615) 355-6063, press "1"
Email support@betterwater.com

Customer Service:
Phone (615) 355-6063, press "3"
Email customerservice@betterwater.com

Technical Phone Support

Support is available regarding all Better Water LLC systems, **24 hours a day, 7 days a week.**

- Normal business hours are [Monday through Friday](#) from **8:00 am until 3:30 pm, Central Standard Time** (*excluding holidays*)

Call (615) 355-6063, press "1" for Technical Support

Emergency assistance is available after normal business hours (*including holidays*) by calling **(615) 708-8627**.

Technical Support Info Online

Our website, www.betterwater.com, which is updated frequently, contains a wealth of technical support information on the **SUPPORT** tab and includes:

- Operator and Service Manuals
- Consumables and Accessories Lists
- Technical Service Bulletins

For your convenience there are also online forms for placing **Orders** and requesting **Returned Goods Authorization**. These are Adobe forms that can be downloaded and either faxed or emailed to us.



Specific Contacts

Technical Support	Phone (615) 355-6063, option "1"
	Email support@betterwater.com
To Place an Order (purchase orders)	Fax (615) 355-6065
	Email orders@betterwater.com
	Phone (615) 355-6063
Customer Service (returns)	Phone (615) 355-6063, option "2"
	Fax (615) 355-6065
	Email customerservice@betterwater.com

Website www.betterwater.com

Helpful information and forms that can be found on our website:

- Operator & Service Manuals
- Technical Service Bulletins
- Consumables and Replacement Parts List
- Brochures
- Order Form
- Return Goods Authorization Request Form

Introduction

The Better Water LLC Bicarb unit is manufactured to the utmost quality. With proper care, preventative maintenance, and proper use, it should provide you with a very effective means of mixing the bicarbonate solution for dialysis treatments.

Before starting you should first read and have a thorough understanding of this entire Operator Manual. It describes in detail the steps and procedures for safe usage of the Bicarb unit.

Once the this device has been delivered, it is the responsibility of the Medical Director to ensure that it is used, monitored, and maintained in such a manner so as to satisfy all applicable standards. Guidelines and other related information are available from:

- Food and Drug Administration (FDA)
- National Association of Nephrology Technicians/Technologists (NANT)
- Association for the Advancement of Medical Instrumentation (AAMI)



NOTE concerning pictures in this manual:

Pictures of devices and components may vary slightly due to product changes, and therefore should be for general reference only. Information concerning their use, functionality, or replacement will not differ unless noted.

WARNINGS



1. It is unsafe to operate or service this device without first reading and understanding the **entire** Operator and Service Manuals. Keep this manual and other associated documentation for future reference.
2. Misuse, improper operation, and/or improper monitoring of this system could result in serious injury, death, or other serious reactions to patients undergoing hemodialysis treatment.
3. Misuse, improper use or handling of disinfectants and chemical cleaning solutions could result in serious injury or even death. You must comply with the information contained in the Material Safety Data Sheet (MSDS) for the chemical being used.
4. To avoid electrical shock hazard, do not operate this device when the covers or panels are removed.

5.  **ELECTROMAGNETIC INTERFERENCE: This device can create and radiate radio frequency energy and may cause harmful interference if not installed according to the manufacturer's instructions.**

CAUTIONS



1. When used as a medical device, federal law restricts this device to sale by or on the authority of a physician. Per CFR 801.109 (b)(1).
2. Improper operation of this device could result in a low or no-flow alarm on the dialysis machines.
3. Misuse or improper operation of this device will void any warranty.
4. Where water is mentioned, unless otherwise noted, it must be AAMI standard quality water.
5. Electrical and plumbing connections must adhere to local statutes and any facility codes. Connect this device to a proper ground connection in accordance with the National Electrical Code. Do not remove the ground wire or ground plug. Do not use an extension cord with this device.
6. Do not remove any Caution, Warning or any other descriptive labels from the device.
7. Do not operate this device in an explosive environment or in the presence of flammable materials. Do not use this device to store, mix or transfer flammable liquids.
8. Movement or vibrations during shipment may cause connections to loosen.
9. Do not operate this unit in an environment where temperatures may be below 50° F or above 90° F.
10. This device should not be used for purposes outside the device's stated applications, specifications or limitations.

MODELS

There are two models of the Dual Bicarb unit; the 60 gallon and the 100 gallon. The operation, service, and replacement parts of these two units are the same with the only difference being the size of the tanks.



Dual 60 Gallon Bicarb Unit
Part#
EQASSY60BC-2TNK-SP



Dual 100 Gallon Bicarb Unit
Part#
EQASSY100BC-2TNK-SP

IMPORTANT INFORMATION FOR SUPPORT

Adhered to the front of each Bicarb unit is a label containing important information relating to the specific Bicarb unit, and details both the **Model** and **Serial Number**. Both of these pieces of information are very important in obtaining support, determining warranty, and properly servicing the Bicarb unit. Please have this information available if you contact Technical Support.



The first four numbers in the serial number denote the year and month the device was manufactured. *In the example above the Dual 60 Gallon Bicarb unit, was produced in **2016**, in the month of **November**.*

PRODUCT DESCRIPTION

The Dual Tank Bicarb Mix and Delivery System is composed of three integrated parts:

- Dual Tank Unit with Mixers and Pump
- Control Box
- Loop Header

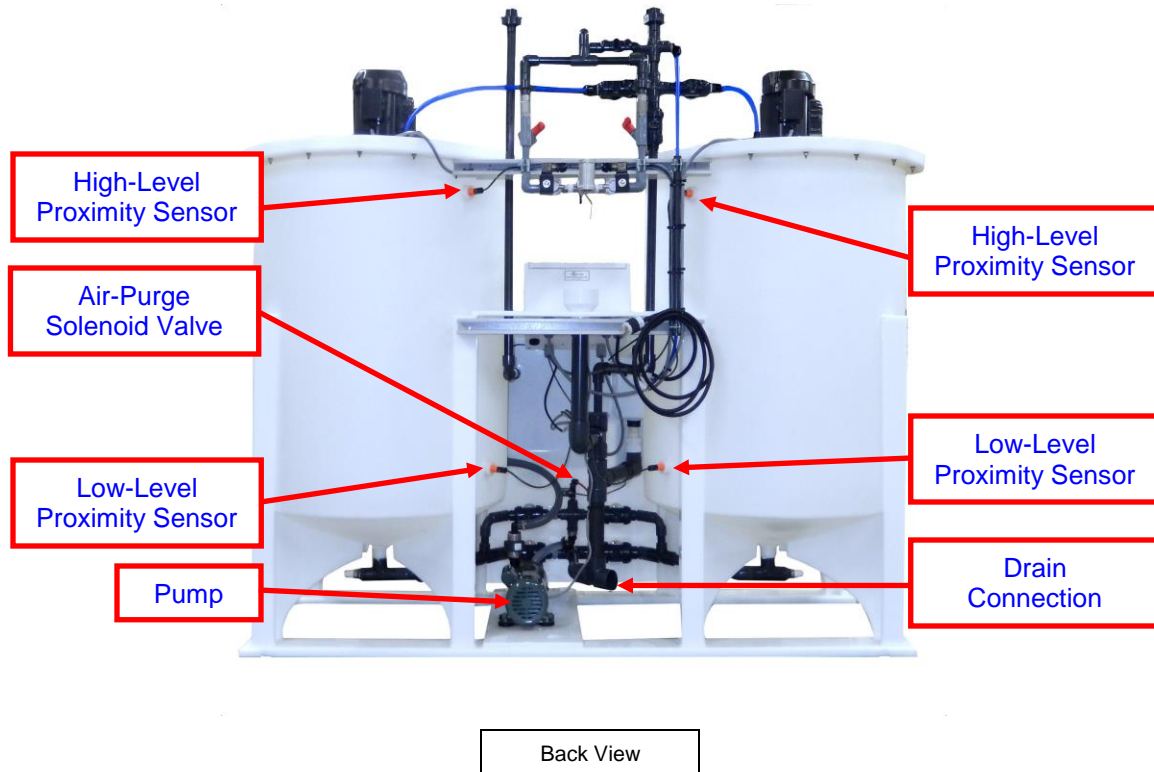
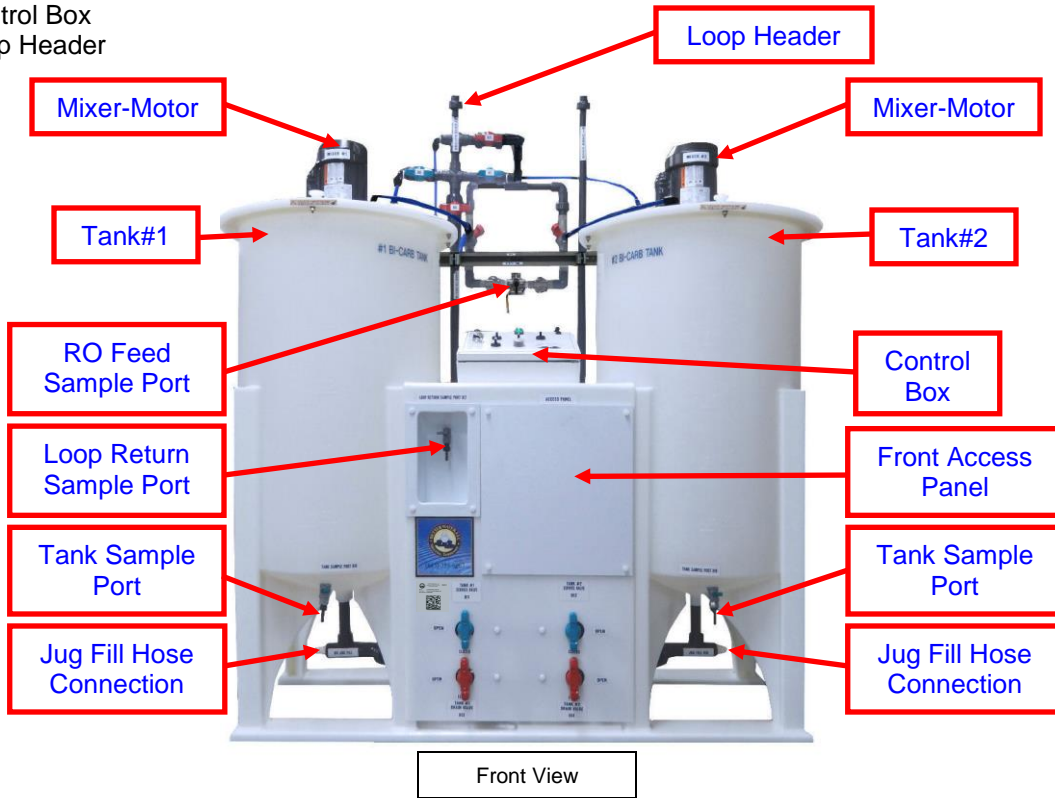

DUAL TANK UNIT with Mixers and Pump

The Dual Tank Bicarb unit consists of two tanks that are constructed entirely of polyethelene and are not susceptible to corrosion. The tanks are plumbed together in such a way as to allow the system to be used in a number of combinations. For example, mixing in Tank#1, while running off of Tank#2. The user will fill the tanks with the appropriate amount of DI or RO water, as indicated by the marks on the side of the tanks for the amount of bicarbonate they wish to mix. Switches on the Control Box and Valves settings control the different operational combinations. **Spray-Balls** are used inside each tank to facilitate a thorough and effective rinse of the tank walls and underside of the tank lids.

The front half of the lid on each tank is hinged for easy access when adding the bicarbonate powder-mix. The desired quantity of bicarbonate solution must first be mixed, after which it can be circulated via the pump.

The unit is equipped with a **Tank Drain Valve**, and will be plumbed to a suitable drain and has a **1" Inlet Port** which will be plumbed from your AAMI standard quality water supply via a 1" tee.

The unit is equipped with a **Mixer with propellers**, on each Tank, for mixing the bicarbonate solution. These Mixers are 1/4 HP, 110 VAC motors (220V model also available), equipped with a 316 stainless steel shafts and couplings, and three polypropylene propellers each. Automatic timers for these mixers are incorporated into the Smart Relay and preset at the factory for 10 minutes. This time is not user adjustable.

The **Jug-Fill Hose** can be attached to quick-disconnect fittings located on left and right sides of the bottom of the tanks for easy filling of jugs if necessary.

This system has a **High-Level Shut-Off** feature which is designed to prevent the tanks from overflowing when filling. This option can be overridden during disinfecting. This High-Level Shut-Off consists of Level Sensors, and two 24 VAC Solenoid Valves, and is controlled by the Tank Fill Switch and the Disinfect Key Switch.

- The Level Sensors are located on the back of the Tanks and when activated will stop the filling of the Tanks to prevent it from overflowing.
- The 24 VAC Solenoid Valves are located on the fill line prior to the Fill Valve.

The unit also has **Low-Level Sensor** in each Tank, which will sound an audible alarm when solution is drawn down to approximately 10 gallons or less in 60 gallon tanks or 20 gallons or less in 100 gallon tanks, indicating their almost empty. These alarms are operated by a 24 VAC circuit inside the Control Box. Since only one tank alarm can be utilized at a time, it is important to verify that the appropriate tank alarm is selected.

The **Recirculation Pump** is a 1/3 HP/110 VAC (*other voltage models also available*) magnetically driven pump, which is protected from running dry or dead-heading by a flow-switch. It pumps the solution from the tanks through the distribution loop. A larger pump is also available for longer loops. There is also a solenoid valve on the inlet side of the pump which performs an air-purge when pump starts to prevent air-locking.

The unit is equipped with four **Sample Ports**; one for each tank, as well as a **RO Feed Sample** and a **Loop Return Sample** for easy sampling.

NOTE: This Bicarb unit is NOT heat disinfectable, but it is compatible with most RO Water Loop Heat Disinfect Systems. The only part of this system that is tolerant of water heated to 194° F is the Water Supply Loop.

CONTROL BOX

The Control Box is integrated into the Bicarb unit. It has the necessary switches to control the Mixer, Tank Alarm, Tank Fill, Pump, and Disinfect operation.

Each of these switches and controls are described in detail in following sections.



LOOP HEADER

The Loop Header serves to connect the two Tanks to the Distribution Loop. It contains the necessary valves to control the flow of water to the Tanks and bicarbonate solution from the Tanks.

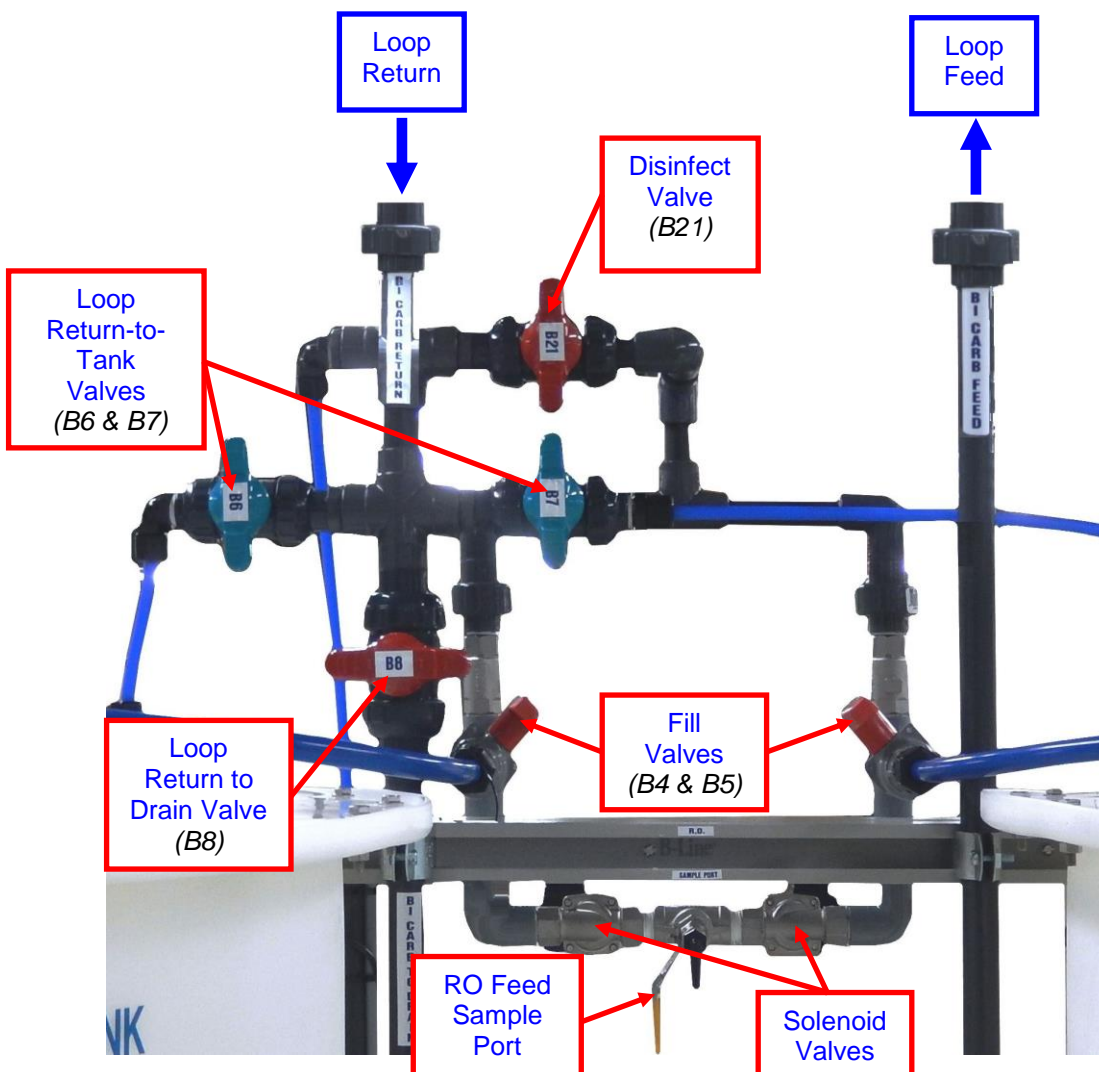

Better Water LLC; rev. Jun 2017

BICARB REMOTE ALARM BOX (optional)

The Bicarb Remote Alarm Box is an optional piece of equipment. This device is a box containing a light and an audible alarm that is usually located on the patient floor, where it can be easily monitored by clinic personnel. This box is equipped with audible and visual alarms that monitor the Low Level Alarm on the Bicarb unit. It requires no additional power but receives 24 VAC power and signals from the Bicarb unit via the Remote Alarm Wire.

The alarm can be temporarily muted by pressing the **MUTE button**.



part#
EQASSYBCB01709
Bicarb Remote Alarm Box

GENERAL REQUIREMENTS & SPECIFICATIONS

1. Water Connections:

- a. RO Water Inlet and Outlet Connections: 1" stainless steel tee, female pipe thread
- b. Feed and Return Line Connections: 3/4" Schedule 80 PVC pipe, female socket, solvent weld

2. Electrical Requirements:

- a. Domestic Models: 115 VAC, 20 AMP, Dedicated GFCI Outlet (220V models also available)
- b. Location: 7' above finished floor, on the wall, in the center of the unit

3. Drain Requirements:

- a. 12" x 12" floor sink preferred
- b. Drain Connection: In close proximity to the Bicarb unit
1 1/2" Schedule 80 PVC pipe.
Must be an open-drain (*air-gapped*).

4. Floor Space:

- a. 60 Gallon Dual Tank: Height 70" x Length 70" x Width (depth) 33"
- b. 100 Gallon Dual Tank: Height 70" x Length 81" x Width (depth) 40"

5. Operating Weight:

- a. 60 Gallon Dual Tank: 1350 lbs
- b. 100 Gallon Dual Tank: 2100 lbs

OPERATION

Before you start using this device, operators must read and understand this manual in its entirety. This manual of Operator's Instructions describes in considerable detail all of the steps and procedures required to **safely** operate this device. With proper operation, maintenance, and care, this device should give you years of reliable service.

It is **unsafe** to operate this device without a basic understanding of water treatment and a thorough understanding of the contents of this manual. Inadequately treated water for hemodialysis poses a severe threat to the health and safety of hemodialysis patients. Education and training of the staff in these facilities is critical given the technically complex subject of water treatment. Guidelines and other related information are available from:

- Food and Drug Administration (FDA)
- National Association of Nephrology Technicians/Technologists (NANT)
- Association for the Advancement of Medical Instrumentation (AAMI)

Incoming tap water contaminants, temperature, pH, pressure, and flow-rates have a direct impact on the quality and quantity of the RO output. The operator must be aware of changing tap water conditions. This can be easily accomplished with good, two-way communications with the local municipal water supplier and with routine testing of the tap water.

BICARB UNIT VALVES LEGEND & DESCRIPTIONS

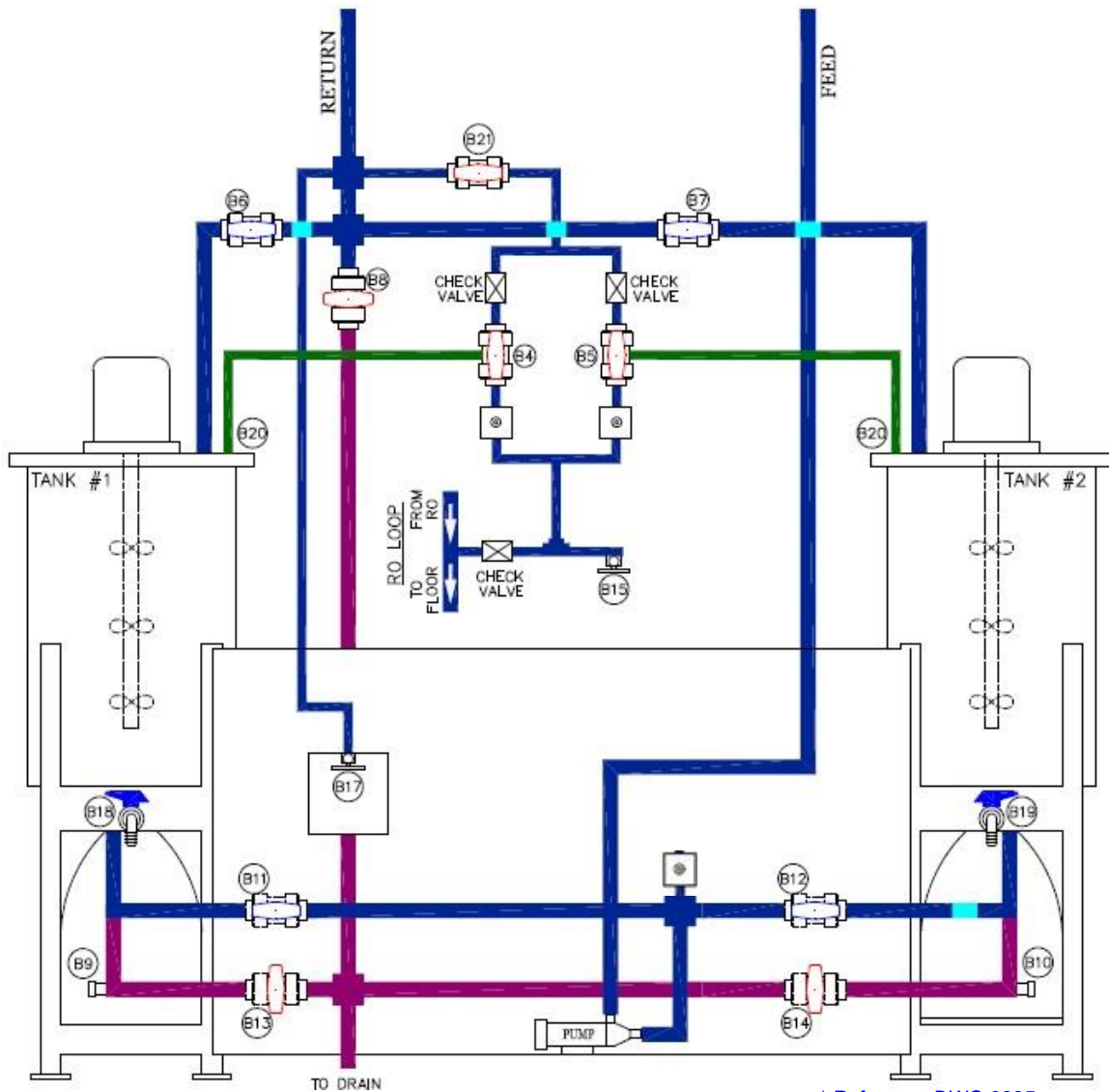

VALVE	DESCRIPTION	VALVE	DESCRIPTION
B4	Tank#1 Fill Valve	B13	Tank#1 Drain Valve
B5	Tank#2 Fill Valve	B14	Tank#2 Drain Valve
B6	Tank#1 Loop Return Valve	B15	RO Feed Sample Port
B7	Tank#2 Loop Return Valve	B17	Loop Return Sample Port
B8	Loop Return to Drain Valve	B18	Tank#1 Sample Port
B9	Tank#1 Jug Fill Valve	B19	Tank#2 Sample Port
B10	Tank#2 Jug Fill Valve	B20	Fill Flow Control (x2) (if used)
B11	Tank#1 Pump Service Valve	B21	Disinfect Valve
B12	Tank#2 Pump Service Valve		

- B4 Tank#1 Fill Valve**
Opening this valve allows Tank #1 to be filled. Tank Fill Switch on Control Panel must be in the Tank #1 position to fill. Once the level in the tank reaches the High level Sensor, the Solenoid Valve will close and water flow will cease.
- B5 Tank#2 Fill Valve**
Opening this valve allows Tank #2 to be filled. Tank Fill Switch on Control Panel must be in the Tank #2 position to fill. Once the level in the tank reaches the High level Sensor, the Solenoid Valve will close and water flow will cease.
- B6 Tank#1 Loop Return Valve**
When the pump is operating and when this valve is in the OPEN position, liquid will return to Tank #1.
- B7 Tank#2 Loop Return Valve**
When the pump is operating and when this valve is in the OPEN position, liquid will return to Tank #2.
- B8 Loop Return to Drain Valve**
When the pump is operating and when this valve is in the OPEN position, liquid will return to Drain.
- B9 Tank #1 Jug Fill Valve**
This valve is used to fill jugs from Tank #1 if needed.
- B10 Tank #2 Jug Fill Valve**
This valve is used to fill jugs from Tank #2 if needed.
- B11 Tank #1 Pump Service Valve**
This Valve is used to allow liquid to be pumped from Tank #1 through the pump and to the distribution Loop. When this valve is closed, Tank #1 will be isolated from the pump and distribution loop.
- B12 Tank #2 Pump Service Valve**
This Valve is used to allow liquid to be pumped from Tank #2 through the pump and to the distribution Loop. When this valve is closed, Tank #2 will be isolated from the pump and distribution loop.
- B13 Tank #1 Drain Valve**
This Valve is used to drain all liquid from Tank #1.
- B14 Tank #2 Drain Valve**
This Valve is used to drain all liquid from Tank #2.
- B15 RO Feed Sample Port**
This will allow the user to take a sample of the liquid feeding the Bicarb.
- B17 Loop Return Sample Port**
This valve, will allow the user to take a sample of the liquid flowing from the distribution loop. This can be used to verify a bicarbonate solution or to verify the presence or absence of disinfectant solution.
- B18 Tank#1 Sample Port**
Samples can be taken from this port to check the contents of Tank#1.

B19 Tank#2 Sample Port

Samples can be taken from this port to check the contents of Tank#2.

B20 Flow Restrictors (x2)

When installed, the Flow Restrictors are installed to only allow 2gpm to flow through the fill lines. This will prevent the filling process from using too much water from the distribution loop and possibly causing the dialysis machines to go into a "Low Pressure" alarm condition.

B21 Disinfect Valve

Used during the clean/disinfect and after-hours circulation procedures..

FAMILIARIZATION with CONTROL BOX

The following is a brief description of the functions and functional settings of each of the controls on the Control Box. Specific operational functions are described in detail in the sections following, some of which require the controls to be used in conjunction with one another.



TANK ALARM SWITCH

The unit has a Low-Level audible alarm, which is operated on a 24 VAC supplied circuit inside the Control Box. If the alarm switch is on, it will activate when the level in the Tank selected drops to approximately 10 gallons for 60-gallon tanks and 20 gallons for 100-gallon tanks.

- To mute the alarm, turn the switch to **OFF**
 - This switch should be in the OFF position when mixing.
- To activate the alarm for Tank#1, turn the switch to **#1**
- To activate the alarm for Tank#2, turn the switch to **#2**
- When re-circulating solution through the loop, this switch should be in the position specifying the Tank from which the solution is being distributed from.



MIXER CONTROL SWITCH

- To turn the Tank#1 Mixer on, turn the switch to **#1**
- To turn the Tank#2 Mixer on, turn the switch to **#2**
- To turn either mixer off, turn the switch to **OFF**



DISINFECT KEY

The **DISINFECT KEY** is a 2 position key-switch that when in the **ON** position will override the High-Level Sensors so the Tanks can be filled to their capacity for disinfecting and rinsing.

- During normal operation, turn the switch to **OFF**
- During disinfect/cleaning and rinsing, turn the switch to **ON**



NOTE

The **DISINFECT KEY** should **NOT** be left in the switch in the control box, but secured away from the Bicarb unit until a disinfect or cleaning procedure is being performed as part of a safety and security protocol.

OPERATE-OFF SWITCH

This switch controls the operation of the recirculation pump. In order for the pump to be started and run continuously, this switch must be in the **OPERATE** position. If the pump is running, turning the switch to the **OFF** position will stop the pump.

- This switch must be in the **OPERATE** position for the pump to start
- To stop the pump, turn this switch to **OFF**

**TANK FILL SWITCH**

This switch controls the Solenoid Valves and works in-conjunction with the High Level Sensors to prevent overflows.

- To fill Tank#1, turn the switch to **#1**
- To fill Tank#2, turn the switch to **#2**
- To stop filling the Tanks, turn the switch to **OFF**

**PUMP START BUTTON**

This button is used in conjunction with the **OPERATE-OFF SWITCH**.

- To start the pump for recirculation, the **OPERATE-OFF SWITCH** must be in the **OPERATE** position. Then press the **PUMP START** button. This will open a solenoid valve on the inlet side of the pump to initiate a 20 second air-purge to reduce air-locking of the pump. After the air-purge, the pump will then start and the green **PUMP INDICATOR Light** will illuminate.
- If the pump turns off shortly after starting it, simply press the PUMP START button again to restart.
- To stop the pump, turn the **OPERATE-OFF SWITCH** to **OFF**

**CAUTION**

The pump is equipped with a Flow-Switch which will not allow the pump to run dry or dead-head (*valve downstream of the pump discharge is closed*). Even given this feature, the pump should not be run dry which can damage the pump. The pump should never be run to drain the tanks.

NOTE

When the PUMP START Button is pressed, the air purge solenoid valve will open to begin a 20 second air purge prior to the pump starting. Once the pump starts, this air-purge continues another 30 seconds.

Do not assume the pump didn't start until after allowing for the initial 20 second air purge cycle to complete.

SILENCING an ALARM

Alarms will sound for the following conditions:

- Low-Level Alarm – Liquid in a tank falls below approximately 10 gallons for 60-gallon tanks and 20 gallons for 100-gallon tanks.

1. The alarm may be muted by turning the **TANK ALARM Switch** to **OFF**



AFTER-HOURS CIRCULATION DRAIN

If this is the first use after an After-Hours Circulation, the Bicarb Tanks and Distribution Loop must be drained.

1. Close **ALL VALVES** and turn all **SWITCHES/KEYS** to the **OFF** position.
2. Open the following valves:
 - Open **Tank#1 Drain Valve (B13)**
 - Open **Tank#2 Drain Valve (B14)**
3. Allow the tanks and loop to drain completely.
4. Once the tanks and loop are fully drained, close the following valves:
 - Close **Tank#1 Drain Valve (B13)**
 - Close **Tank#2 Drain Valve (B14)**

FILLING TANK#1

1. Close **ALL VALVES** and turn all **SWITCHES/KEYS** to the **OFF** position.
2. Turn the **TANK FILL Switch** to **#1**
3. Open **Tank#1 Fill Valve (B4)**, and fill the tank with the desired amount of water.
4. Close **Tank#1 Fill Valve (B4)** when the desired amount of water is reached.
 - The Tank Drain Valve may be opened if necessary to drain any excess water to the desired level.
5. Turn the **TANK FILL Switch** to **OFF**



CAUTION

When not filling the tank, Tank#1 Fill Valve (B4) should be CLOSED and the Tank Fill Switch should be in the OFF position, to prevent accidental dilution of either the bicarbonate solution or disinfectant/cleaner in the tank.

FILLING TANK#2

1. Close **ALL VALVES** and turn all **SWITCHES/KEYS** to the **OFF** position.
2. Turn the **TANK FILL Switch** to **#2**
3. Slowly open **Tank#2 Fill Valve (B5)**, and fill the tank with the desired amount of water.
4. Close **Tank#2 Fill Valve (B5)** when the desired amount of water is reached.
 - The Tank Drain Valve may be opened if necessary to drain any excess water to the desired level.
5. Turn the **TANK FILL Switch** to **OFF**



CAUTION

When not filling the tank, Tank#2 Fill Valve (B5) should be CLOSED and the Tank Fill Switch should be in the OFF position, to prevent accidental dilution of either the bicarbonate solution or disinfectant/cleaner in the tank.

MIXING BICARBONATE SOLUTION in TANK#1 or TANK#2

Before mixing, make sure that the tank is empty and clean! Follow the bicarbonate powder manufacturer's instructions for mixing ratios. This device does not control or verify the quality of the bicarbonate solution. The operator is responsible for mixture ratios and verification.

Do not open bags of bicarbonate powder over the open tank, because torn pieces of the bag and debris can fall into the tank and cause damage to the pump.

CAUTION

Mixed bicarbonate solution has a limited storage time. Consult the bicarbonate powder manufacturer's recommendations for storage time limits.

1. Close **ALL VALVES** and turn all **SWITCHES/KEYS** to the **OFF** position.
2. Fill the desired tank according to the instructions in the "*Filling Tank#1*" or "*Filling Tank#2*" sections.
3. If mixing in Tank#1, turn that mixer on by turning the **MIXER CONTROL Switch** to **#1**, which starts the mixer and a preset 10-minute timer.

- OR -

 If mixing in Tank#2, turn that mixer on by turning the **MIXER CONTROL Switch** to **#2**, which starts the mixer and a preset 10-minute timer.
4. Open the Lid to the Tank and slowly pour in the appropriate amount of bicarbonate powder into the Tank. Ensure that the Mixer is operating before pouring the powder in.



5. After the mixing cycle is complete and the timer has expired the mixer will automatically turn off. Turn the **MIXER CONTROL Switch** to **OFF**.

- *NOTE: The mixer timers are preset at the factory for 10 minutes (each mixer, and are not user adjustable).*



6. Verify that the solution is properly mixed by testing a sample from the Tank Sample Port, located on the front of the Bicarb unit. Since this valve is located on the bottom of the tank this is an accurate sampling of what the patient will actually receive.

NOTE: There are several methods for testing/verifying that the bicarbonate solution is mixed properly, but Better Water LLC does not recommend a specific method. The bicarbonate manufacturer's instructions should be followed.

7. Bicarbonate solution is ready for use.

PRIMING the LOOP

Once bicarbonate has been mixed, verified, and ready for distribution, the loop should be primed. Since there is always a certain amount of water in the loop prior to distribution, this water should be discharged to drain rather than be allowed to return to the distribution tank, to prevent dilution of the newly mixed solution. This drain should continue until the newly mixed solution is sufficiently distributed within the loop until all points of use within the loop have conductivity equal to the newly mixed solution.

This is accomplished by setting the appropriate valves to send the solution returning from the loop to drain, then starting the pump. The solution should be run to drain and conductivity checked at the Loop Return Sample Port (B17), until conductivity equality is achieved between the solution returning from the loop and the newly mixed solution. Once conductivity equality is achieved, the appropriate valves should be set to stop the draining and return the solution to the tank containing the newly mixed solution. The sections to follow detail how to setup for operation from either or both tanks and include this priming process.

SETUP for ONE-TANK OPERATION FROM TANK#1

The following is the valve and switch setup required to feed the distribution loop from Tank#1, with the return coming back to Tank#1.

1. Close **ALL VALVES** and turn all **SWITCHES/KEYS** to the **OFF** position.

2. Open the following valves:

- Open **Tank#1 Pump Service Valve (B11)**
- Open **Loop Return to Drain Valve (B8)**

3. Control Box Switch settings:

- **DISINFECT KEY** – **OFF** position
- **TANK ALARM Switch** - **#1** position
- **TANK FILL Switch** – **OFF** position



4. Start the pump:

- Turn the **OPERATE-OFF Switch** to **OPERATE**
- Press the **PUMP START Button**. After the air-purge cycle completes, the pump will start.



5. To stop the Pump, turn the **OPERATE-OFF Switch** to **OFF**



6. Once conductivity equality is achieved between the solution returning from the loop return and the newly mixed solution...

- Open **Tank#1 Loop Return Valve (B6)**
- Close **Loop Return to Drain Valve (B8)**

SETUP for ONE-TANK OPERATION FROM TANK#2

The following is the valve and switch setup required to feed the distribution loop from Tank#2, with the return coming back to Tank#2.

1. Close **ALL VALVES** and turn all **SWITCHES/KEYS** to the **OFF** position.

2. Open the following valves:

- Open **Tank#2 Pump Service Valve (B12)**
- Open **Loop Return to Drain Valve (B8)**

3. Control Box Switch settings:

- **DISINFECT KEY** – **OFF** position
- **TANK ALARM Switch** - **#2** position
- **TANK FILL Switch** – **OFF** position



4. Start the pump:

- Turn the **OPERATE-OFF Switch** to **OPERATE**
- Press the **PUMP START Button**. After the air-purge cycle completes, the pump will start.



5. To stop the Pump, turn the **OPERATE-OFF Switch** to **OFF**



6. Once conductivity equality is achieved between at the solution returning from the loop return and the newly mixed solution...

- Open **Tank#2 Loop Return Valve (B7)**
- Close **Loop Return to Drain Valve (B8)**

SETUP for SIMULTANEOUS TWO-TANK OPERATION

The following is the valve and switch setup required to feed the distribution loop from both Tanks, with the return coming back to both Tanks.

1. Close **ALL VALVES** and turn all **SWITCHES/KEYS** to the **OFF** position.

2. Open the following valves:

- Open **Tank#1 Pump Service Valve (B11)**
- Open **Tank#2 Pump Service Valve (B12)**
- Open **Loop Return to Drain Valve (B8)**

3. Control Box Switch settings:

- **DISINFECT KEY** – **OFF** position
- **TANK ALARM Switch** – either position **#1** or **#2** position
- **TANK FILL Switch** – **OFF** position



4. Start the pump:

- Turn the **OPERATE-OFF Switch** to **OPERATE**
- Press the **PUMP START Button**. After the air-purge cycle completes, the pump will start.

5. To stop the Pump, turn the **OPERATE-OFF Switch** to **OFF**

6. Once conductivity equality is achieved between at the solution returning from the loop return and the newly mixed solution...

- Open **Tank#1 Loop Return Valve (B6)**
- Open **Tank#2 Loop Return Valve (B7)**
- Close **Loop Return to Drain Valve (B8)**

STARTING the PUMP for DISTRIBUTION to the LOOP

Before attempting to start the pump, ensure the following according to the operation being performed:

- The Tank(s) contain bicarbonate solution, RO water, or disinfect/cleaning solution, and are not empty.

*** NOTE:** The pump is equipped with a Flow Switch which will not allow the pump to run if the tank is empty, or if the pump is dead-headed (valve downstream of the pump discharge is closed). Verify the appropriate valves are opened and/or closed as specified for the required operation.

1. Start the pump:

- Turn the **OPERATE-OFF Switch** to **OPERATE**
- Press the **PUMP START Button**. After the air-purge cycle completes, the pump will start. If the pump turns off shortly after starting it, simply press the PUMP START button again to restart.

2. To stop the Pump, turn the **OPERATE-OFF Switch** to **OFF**

*** NOTE:** The pump should not be run dry, and should be stopped before dry.



END of TREATMENT DAY RINSE and DRAIN

To prevent bicarbonate build-up on internal surfaces and parts the Bicarb unit and loop should be thoroughly rinsed and drained at the end of each treatment day before after-hours circulation.

1. Close **ALL VALVES** and turn all **SWITCHES/KEYS** to the **OFF** position.

2. Allow the tanks and loop to drain by opening the following valves:

- Open **Tank#1 Drain Valve (B13)**
- Open **Tank#2 Drain Valve (B14)**

3. Allow the tanks and loop to drain completely.

4. Rinse down the entire inside of each tank by doing the following:

- Turn **TANK FILL SWITCH** to **#1** and open **Tank#1 Fill Valve (B4)**
- Allow Tank#1 to rinse, then close **Tank#1 Fill Valve (B4)**
- Turn **TANK FILL SWITCH** to **#2** and open **Tank#2 Fill Valve (B5)**



- Allow Tank#1 to rinse, then close **Tank#2 Fill Valve (B5)**
- When finished turn **TANK FILL SWITCH** to the **OFF** position.

5. Allow the tanks to drain completely.

6. Close the following valves:

- Close **Tank#1 Drain Valve (B13)**
- Close **Tank#2 Drain Valve (B14)**

7. Fill Tank#1 with 20 gallons of water per instructions detailed in "Filling Tank#1" section.

8. Fill Tank#2 with 20 gallons of water per instructions detailed in "Filling Tank#2" section.

9. Open the following valves:

- Open **Loop Return to Drain Valve (B8)**
- Open **Tank#1 Pump Service Valve (B11)**
- Open **Tank#2 Pump Service Valve (B12)**

10. Start the pump to circulate the water through the loop and purge to drain.

- Turn the **OPERATE-OFF Switch** to **OPERATE**
- Press the **PUMP START Button**. After the air-purge cycle completes, the pump will start.



11. While the water is moving the following sample ports and jug fills must be quickly rinsed:

- Open **Loop Return Sample Port (B17)** for a few seconds to allow rinse water to flow through, and then close **Loop Return Sample Port (B17)**.
- Open **Tank#1 Tank Sample Port (B18)** for a few seconds to allow rinse water to flow through, and then close **Tank#1 Sample Port (B18)**.
- Open **Tank#2 Tank Sample Port (B19)** for a few seconds to allow rinse water to flow through, and then close **Tank#2 Sample Port (B19)**.

12. Once the water level in the tanks reaches approximately 10 gallons do the following to flush the loop returns:

- Open **Tank#1 Loop Return Valve (B6)**
- Open **Tank#2 Loop Return Valve (B7)**
- Close **Loop Return to Drain Valve (B8)**
- Allow to recirculate for at least 1 minute.

13. Turn the pump off:

- **OPERATE-OFF Switch** to **OFF**



14. Close the following valves:

- Close **Tank#1 Loop Return Valve (B6)**
- Close **Tank#2 Loop Return Valve (B7)**
- Close **Tank#1 Pump Service Valve (B11)**
- Close **Tank#2 Pump Service Valve (B12)**

15. Open the following valves to drain the tanks.

- Open **Tank#1 Drain Valve (B13)**
- Open **Tank#2 Drain Valve (B14)**

16. Once the tanks are completely drained close the following valves:

- Close **Tank#1 Drain Valve (B13)**
- Close **Tank#2 Drain Valve (B14)**

AFTER-HOURS CIRCULATION

During after-hours, rather than let the Bicarb unit sit unused, to minimize microbial growth, it is recommended that both tanks be partially filled with water and circulate from each through the loop.

1. Verify that “*End of Treatment Day Rinse and Drain*” procedure, as previously detailed in said section, has been completed otherwise perform before proceeding.
2. Close **ALL VALVES** and turn all **SWITCHES/KEYS** to the **OFF** position.
3. Fill Tank#1 with 20 gallons of water per instructions detailed in “*Filling Tank#1*” section.
4. Fill Tank#2 with 20 gallons of water per instructions detailed in “*Filling Tank#2*” section.
5. Open the following valves:
 - Open **Tank#1 Fill Valve (B4)**
 - Open **Tank#2 Fill Valve (B5)**
 - Open **Tank#1 Pump Service Valve (B11)**
 - Open **Tank#2 Pump Service Valve (B12)**
 - Open **Disinfect Valve (B21)**
6. Start the pump to circulate the water through the loop from both tanks and back to both tanks.
 - Turn the **OPERATE-OFF Switch** to **OPERATE**
 - Press the **PUMP START Button**. After the air-purge cycle completes, the pump will start.



7. Let the system continue in this mode until ready for use at a later time, at which time the “*After-Hours Circulation Drain*” procedure should be performed as previously detailed in said section.

GENERAL CLEANING and DISINFECTING INFORMATION

To perform at peak efficiency the Bicarb unit must periodically be cleaned and disinfected.

The **Cleaning Process** is designed to remove bicarbonate and mineral build-up on internal surfaces as well as the flow-switch and pump. It is recommended that unit be cleaned **Monthly** with vinegar, citric acid, or a 1% peracetic acid solution.

The **Disinfecting Process** is designed to significantly reduce bacteria and endotoxins that may build-up in the water and on the internal surfaces in the form of bio-film. The importance of regular and frequent disinfection cannot be minimized due to the risk associated with bacteria proliferation. It is recommended that the unit be disinfected **Weekly** with bleach or an approved cold-sterilant disinfectant.

Bicarb units may require more frequent cleaning and disinfecting, which is ultimately the responsibility of the Medical Director and is typically based on water testing.

DISINFECTING with BLEACH

The use of typical household bleach (5.25%) is common for use in disinfecting water treatment systems for hemodialysis. Bleach is a cost effective disinfectant and generally produces satisfactory results. Varying concentrations of Sodium Hypochlorite (*bleach*) are used among dialysis facilities for disinfection. Generally speaking, the greater the concentration the shorter the circulation time.

- a. 5.25% household bleach is 52,500 ppm Sodium Hypochlorite
- b. 6.25% household bleach is 62,500 ppm Sodium Hypochlorite
- c. 8.25% household bleach is 82,500 ppm Sodium Hypochlorite

Better Water LLC recommends using IRON FREE bleach. Care should be taken to select iron free bleach because many discount or generic brands will have high iron content. Iron will be harmful to the equipment and shorten its lifespan.

*** WARNING: DO NOT USE "SPASH-LESS" BLEACH. The content of "splash-less" bleach may damage the equipment, and will create foam.**

BLEACH SOLUTION FOR BICARB UNITS

- a. Better Water LLC recommends a 525 ppm solution of sodium hypochlorite (*bleach*)

This is 1 gallon (128 ounces) of bleach per 100 gallons of water or a **1:100 dilution**.

Currently there are 3 major bleach concentrations readily available on the market. Below are the dilution formulas required for each concentration percentage:

- | | |
|--------------------------|---|
| 5.25% = 525 ppm dilution | Water Gallons x 1.28 = ounces of bleach 5.25% |
| 6.25% = 625 ppm dilution | Water Gallons x 0.96 = ounces of bleach 6.25% |
| 8.25% = 825 ppm dilution | Water Gallons x 0.76 = ounces of bleach 8.25% |

*** Total water gallons should include gallons in the tank as well as the loop.**

- b. Recommended circulation time is **30-60 minutes**

*** See Appendix A for other bleach dilution ratios and pipe volume calculations, and 3 feet per second flow velocity rates if needed.**

NOTE

This Bicarb unit is NOT heat disinfected, but it is compatible with most RO Water Loop Heat Disinfect Systems. The only part of this system that is tolerant of water heated to 194° F is the Water Supply Loop.

DISINFECTING PROCEDURE

See **GENERAL CLEANING** and **DISINFECTING INFORMATION** section for recommendations and details for this procedure.

WARNING

Chemical cleaners and disinfectants can cause serious injury or death.

Proper protective equipment must be used.

The preparation of these chemical solutions must be done in accordance with the specifications established for the particular chemical.

These chemical solutions must be handled in accordance with their Material Safety Data Sheet (MSDS).

These procedures should be performed by trained and qualified technicians.

WARNING

Do not disinfect or clean the Bicarb unit or distribution loop while patients are dialyzing.

FOR DISINFECTING. Use a proper dilution of sodium hypochlorite (*bleach*) based on strength as previously detailed.

- *Other approved cold-sterilant disinfectants can be used following the manufacturer's instructions for dilution ratios and use.*

1. Verify that "End of Treatment Day Rinse and Drain" procedure, as previously detailed in said section, has been completed otherwise perform before proceeding.

2. Close **ALL VALVES** and turn all **SWITCHES/KEYS** to the **OFF** position.

3. Turn **DISINFECT Key Switch** to **ON**.

- *NOTE: Take care not to overflow the Tanks when in this mode, when the High Level Sensor is overridden.*



CAUTION – SPRAY HAZARD: Do not lift lid while sprayers are in use.

PREPARE DISINFECTANT PROCEDURE

4. Fill each Tank with the 30 gallons of water.

- Open the **Tank#1 Fill Valve (B4)**.
- When properly filled, close **Tank#1 Fill Valve (B4)**
- Open the **Tank#2 Fill Valve (B5)**.
- When properly filled, close **Tank#2 Fill Valve (B5)**.

5. Add disinfectant to Tank#1 and mix.

- Turn the **MIXER CONTROL Switch** to **#1**.



- Lift the Tank#1 Lid and slowly add the appropriate amount of disinfectant to the tank.
- *NOTE: Take into account the volume of water in the distribution loop, this will provide the system with the appropriate amount of disinfectant for the Bicarb unit.*
- Let the solution mix for approximately one minute, and then turn the **MIXER CONTROL Switch** to **OFF**.



6. Add disinfectant to Tank#2 and mix.
- Turn the **MIXER CONTROL Switch** to **#2**.
 - Lift the Tank#2 Lid and slowly add the appropriate amount of disinfectant to the tank
 - *NOTE: Take into account the volume of water in the distribution loop, this will provide the system with the appropriate amount of disinfectant for the Bicarb unit.*
 - Let the solution mix for approximately one minute, and then turn the **MIXER CONTROL Switch** to **OFF**.



DISINFECT BICARB UNIT and LOOP PROCEDURE

7. Open the following valves:

- Open **Loop Return to Drain Valve (B8)**
- Open **Tank#1 Pump Service Valve (B11)**
- Open **Tank#2 Pump Service Valve (B12)**

8. Start the pump to circulate the solution through the loop and to drain:

- Turn the **OPERATE-OFF Switch** to **OPERATE**
- Press the **PUMP START Button**. After the air-purge cycle completes, the pump will start.



9. Using a disinfectant test kit, test the solution at the **Loop Return Sample Port (B17)** to ensure there is a positive reading at that location. *Allow some time for the solution to flow since the time it will take before a positive reading is seen is also based on the length of the distribution loop, and the time it will take for the solution to flow from the tanks through the loop and back.*

- If a positive reading is not achieved, then add additional disinfectant to each tank, and recheck until a positive reading is achieved.

10. Let the solution go to drain until the Tanks have approximately 15 gallons each, then allow to circulate...

- Open **Tank#1 Loop Return Valve (B6)**
- Open **Tank#2 Loop Return Valve (B7)**
- Close **Loop Return to Drain Valve (B8)**

11. Using a disinfectant test kit, test the solution at the **Loop Return Sample Port (B17)** to ensure there is a positive reading at that location. *Allow some time for the solution to flow since the time it will take before a positive reading is seen is also based on the length of the distribution loop, and the time it will take for the solution to flow from the tanks through the loop and back.*

- If a positive reading is not achieved, then add additional disinfectant to each tank, and recheck until a positive reading is achieved.

12. During circulation, disinfect Jug Fill Hose...

- Obtain a container to collect solution from the Hose.
- Attach the **Jug Fill Hose** to **Tank#1 Jug Fill Quick-Disconnect Fitting** then slowly open the valve on the end of the Jug Fill Hose for approximately 10 seconds to let the solution flow through the hose, then close it.

13. Disinfect the Sample Ports...

- Obtain the same container used above to disinfect the hoses.

- While holding the container under the port, slowly open **Tank#1 Sample Port (B18)** and allow solution to flow through the port into the container for a few seconds then close **Tank#1 Sample Port (B18)**.
- While holding the container under the port, slowly open **Tank#2 Sample Port (B19)** and allow solution to flow through the port into the container for a few seconds then close **Tank#2 Sample Port (B19)**.
- Safely discard the solution in the container.
- Also Open **Loop Return Sample Port (B17)** for a several seconds to allow solution to flow through it, and then close **Loop Return Sample Port (B17)**.

14. Disinfect points of use along distribution loop...

- Obtain the same container used above to disinfect the sample ports.
- Open each of the points of use and allow solution to flow through for several seconds, into the container, until the solution tests positive for disinfectant.
- Safely discard the solution in the container.

15. The solution should circulate in Tanks and Loop for a minimum of 30 minutes up to 60 minutes. This is the total circulation time which started at step 10.

16. Turn **DISINFECT Key Switch** to **OFF**.

- Remove the **Disinfect Key** from the switch and secure it away from the Bicarb unit.

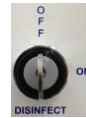

17. Do the following to disinfect the tanks and fill lines:

- Open **Disinfect Valve (B21)**
- Open **Tank#1 Fill Valve (B4)**
- Open **Tank#2 Fill Valve (B5)**
- Close **Tank#1 Loop Return Valve (B6)**
- Close **Tank#2 Loop Return Valve (B7)**
- Allow solution to circulate for 5 minutes.

18. Turn the pump off:

- Turn **OPERATE-OFF Switch** to **OFF**



19. Drain solution from the tanks:

- Open the **Loop Return to Drain Valve (B8)**
- Open **Tank#1 Drain Valve (B13)**
- Open **Tank#2 Drain Valve (B14)**
- Close **Disinfect Valve (B21)**
- Close **Tank#1 Fill Valve (B4)**
- Close **Tank#2 Fill Valve (B5)**
- Let solution run to drain until the tanks are empty.

RINSE PROCEDURE

20. Rinse down the entire inside of each tank by doing the following:

- Turn **TANK FILL SWITCH** to **#1** and open **Tank#1 Fill Valve (B4)**
- Allow Tank#1 to rinse, then close **Tank#1 Fill Valve (B4)**
- Turn **TANK FILL SWITCH** to **#2** and open **Tank#2 Fill Valve (B5)**
- Allow Tank#1 to rinse, then close **Tank#2 Fill Valve (B5)**
- When finished turn **TANK FILL SWITCH** to the **OFF** position.



21. Once the tanks are both empty, close **ALL VALVES**.

22. Fill both tanks with 30 gallons of water:

* *NOTE: Facilities with a large number of stations may require more water to complete the rinse, so adjust accordingly.*

- Open the **Tank#1 Fill Valve (B4)** and turn **TANK FILL Switch** to **#1**
- When properly filled, close **Tank#1 Fill Valve (B4)**
- Open the **Tank#2 Fill Valve (B5)** and turn **TANK FILL Switch** to **#2**
- When properly filled, close **Tank#2 Fill Valve (B5)** and turn **TANK FILL Switch** to **OFF**



23. Open the following valves:

- Open **Tank#1 Pump Service Valve (B11)**
- Open **Tank#2 Pump Service Valve (B12)**
- Open the **Loop Return to Drain Valve (B8)**

24. Start the pump to run the rinse water to drain:

- Turn **OPERATE-OFF Switch** to **OPERATE**
- Press the **PUMP START Button**. After the air-purge cycle completes, the pump will start.

* *Be careful not to let the pump run dry. If during the next several steps, turn the pump off when the water level in either tank drops to 10 gallons. If the rinse is not complete simply return to step 21 and fill with more water to allow for a proper rinse.*



25. While rinse water is draining, rinse Jug Fill Hose...

- Obtain a container to collect solution from the Hose.
- Slowly open the valve on the end of the Jug Fill Hose for approximately 30 seconds to let rinse water flow through the hose, then close it.
- Disconnect and store the Jug Fill Hose.

26. While rinse water is draining, rinse Sample Ports...

- Obtain the same container used above to rinse the hoses.
- While holding the container under the port, slowly open **Tank#1 Sample Port (B18)** and allow rinse water to flow through the port into the container for approximately 30 seconds then close **Tank#1 Sample Port (B18)**.
- While holding the container under the port, slowly open **Tank#2 Sample Port (B19)** and allow rinse water to flow through the port into the container for approximately 30 seconds then close **Tank#2 Sample Port (B19)**.
- Safely discard the solution in the container.
- Also Open **Loop Return Sample Port (B17)** for approximately 30 seconds to allow rinse water to flow through it, and then close **Loop Return Sample Port (B17)**.

27. While rinse water is draining, rinse points of use along distribution loop...

- Obtain the same container used above to rinse the sample ports.
- Open each of the points of use and allow rinse water to flow through for several seconds, into the container, until the solution tests negative for disinfectant.
- Safely discard the solution in the container.

28. Using a disinfectant test kit, verify that there is NO disinfectant present at any of the use points throughout the Bicarb unit and distribution system. Allow water to flow from ports for at least 10 seconds before sampling.

- If any disinfectant detected, then repeat steps 21 through 27 until clear.

29. Do the following to allow the header to rinse.

- Open **Tank#1 Fill Valve (B4)**
- Open **Tank#2 Fill Valve (B5)**
- Open **Disinfect Valve (B21)**

- Close **Loop Return to Drain Valve (B8)**
- Allow to rinse for a minimum of 5 minutes

30. Using a disinfectant test kit, verify from inside each tank from the water coming from the **RO Fill Inlets**, that there is NO chlorine (*bleach*) present at these points.
 - If any disinfectant detected, then repeat step 29 until clear.

31. Turn the pump off when either the above steps are complete or the water level in either tank reaches 10 gallons. If the rinse is not complete and either tanks' water levels reach 10 gallons, simply add a sufficient amount of water to each tank to complete the rinse steps above.
 - Turn **OPERATE-OFF Switch** to **OFF**.



32. Open the following valves and let the tanks drain until empty:

- Open **Tank#1 Drain Valve (B13)**
- Open **Tank#2 Drain Valve (B14)**

33. Once the tanks are empty, close **ALL VALVES**.

34. Do the following to rinse the loop return hose for Tank#2...

- Open **Tank#2 Drain Valve (B14)**
- Open **Tank#1 Fill Valve (B4)** and turn **TANK FILL Switch** to **#1** to fill Tank#1 with approximately 30 gallons of water.
- When properly filled close **Tank#1 Fill Valve (B4)** and turn **TANK FILL Switch** to **OFF**.
- Open **Tank#2 Loop Return Valve (B7)**
- Open **Tank#1 Pump Service Valve (B11)**



35. Start the pump to return water to Tank#2 and on to drain:

- Turn **OPERATE-OFF Switch** to **OPERATE**
- Press the **PUMP START Button**. After the air-purge cycle completes, the pump will start.
- To prevent the pump from running dry, when only 10 gallons of water remain in Tank#1, turn the pump off by turning the **OPERATE-OFF Switch** to **OFF**.



36. Once Tank#2 is empty do the following to rinse the loop return hose for Tank#1...

- Open **Tank#1 Loop Return Valve (B6)**
- Open **Tank#2 Pump Service Valve (B12)**
- Open **Tank#1 Drain Valve (B13)**
- Close **Tank#2 Loop Return Valve (B7)**
- Close **Tank#1 Service Valve (B11)**
- Close **Tank#2 Drain Valve (B14)**
- Open **Tank#2 Fill Valve (B5)** and turn **TANK FILL Switch** to **#2** and fill Tank#2 with approximately 30 gallons of water
- When properly filled close **Tank#2 Fill Valve (B5)** and turn **TANK FILL Switch** to **OFF**.



37. Start the pump:

- Turn **OPERATE-OFF Switch** to **OPERATE**
- Press the **PUMP START Button**. After the air-purge cycle completes, the pump will start.
- To prevent the pump from running dry, when only 10 gallons of water remain in Tank#2, turn the pump off by turning the **OPERATE-OFF Switch** to **OFF**
- Open **Tank#2 Drain Valve (B14)** to drain Tank#2 until empty.



38. Close **ALL VALVES**

FINAL RINSE PROCEDURE

39. Fill each Tank with the approximately 20 gallons of water.

- Open the **Tank#1 Fill Valve (B4)**
- Turn **TANK FILL Switch** to **#1**
- When properly filled, close **Tank#1 Fill Valve (B4)**
- Open **Tank#2 Fill Valve (B5)** and turn **TANK FILL Switch** to **#2**
- When properly filled, close **Tank#2 Fill Valve (B5)** and turn **TANK FILL Switch** to **OFF**



40. Open the following valves:

- Open **Tank#1 Loop Return Valve (B6)**
- Open **Tank#2 Loop Return Valve (B7)**
- Open **Tank#1 Pump Service Valve (B11)**
- Open **Tank#2 Pump Service Valve (B12)**

41. Start the pump:

- Turn **OPERATE-OFF Switch** to **OPERATE**



- Press the **PUMP START Button**. After the air-purge cycle completes, the pump will start.

** Be careful not to let the pump run dry. If during the next step, turn the pump off if the water level in either tank drops to 10 gallons. If the rinse is not complete simply return to step 39 and fill with more water to allow a proper rinse.*

42. Using a disinfectant test kit, verify that there is NO disinfectant present from **Loop Return Sample Port (B17)**. Allow water to flow from ports for at least 10 seconds before sampling.

- If any disinfectant detected, then repeat steps 38 through 41 until clear.

43. Turn the pump off when the water level in either tank reaches 10 gallons:

- Turn **OPERATE-OFF Switch** to **OFF**

** If the rinse is not complete simply return to step 39 and fill with more water to allow for a proper rinse.*



44. Do the following to allow the tanks to drain until empty:

- Open **Loop Return to Drain Valve (B8)**
- Open **Tank#1 Drain Valve (B13)**
- Open **Tank#2 Drain Valve (B14)**
- Close **Tank#1 Loop Return Valve (B6)**
- Close **Tank#2 Loop Return Valve (B7)**

45. Close **ALL VALVES** and turn all **SWITCHES** to **OFF**.

46. Verify that the **DISINFECT Switch** is in the **OFF** position, and that the **Disinfect Key** has been removed from the switch and secured away from the Bicarb unit.

CLEANING PROCEDURE

See **GENERAL CLEANING** and **DISINFECTING INFORMATION** section for recommendations and details for this procedure.

WARNING

Chemical cleaners and disinfectants can cause serious injury or death.

Proper protective equipment must be used.

The preparation of these chemical solutions must be done in accordance with the specifications established for the particular chemical.

These chemical solutions must be handled in accordance with their Material Safety Data Sheet (MSDS).

These procedures should be performed by trained and qualified technicians.

WARNING

Do not disinfect or clean the Bicarb unit or distribution loop while patients are dialyzing.

FOR CLEANING. Use vinegar that contains 5% acetic acid. For 60 gallon tanks add **2750 ml** of vinegar to 50 gallons of water, and for 100 gallon tanks add **4000 ml** of vinegar to 100 gallons of water.

- Citric acid or a 1% peracetic acid solution can also be used following the manufacturer's instructions for dilution ratios and use.

1. Verify that "End of Treatment Day Rinse and Drain" procedure, as previously detailed in said section, has been completed otherwise perform before proceeding.

2. Close **ALL VALVES** and turn all **SWITCHES/KEYS** to the **OFF** position.

3. Turn **DISINFECT Key Switch** to **ON**.

- *NOTE: Take care not to overflow the Tanks when in this mode, when the High Level Sensor is overridden.*



CAUTION – SPRAY HAZARD: Do not lift lid while sprayers are in use.

PREPARE CLEANER PROCEDURE

4. Fill each Tank with the 30 gallons of water.

- Open the **Tank#1 Fill Valve (B4)**.
- When properly filled, close **Tank#1 Fill Valve (B4)**
- Open the **Tank#2 Fill Valve (B5)**.
- When properly filled, close **Tank#2 Fill Valve (B5)**.

5. Using a pH Test Kit, record a baseline reading of the water before cleaner is introduced for comparison with later tests.

- Slowly open the **Tank#1 Sample Port (B18)** and allow water to flow for a minimum of 10 seconds and then take the pH reading. Close **Tank#1 Sample Port (B18)** when finished.

6. Add cleaner to Tank#1 and mix.

- Turn the **MIXER CONTROL Switch** to **#1**.
- Lift the Tank#1 Lid and slowly add the appropriate amount of cleaner to the tank
- *NOTE: Take into account the volume of water in the distribution loop, this will provide the system with the appropriate amount of cleaner for the Bicarb unit.*
- Let the solution mix for approximately one minute, and then turn the **MIXER CONTROL Switch** to **OFF**.



7. Add cleaner to Tank#2 and mix.

- Turn the **MIXER CONTROL Switch** to **#2**.
- Lift the Tank#2 Lid and slowly add the appropriate amount of cleaner to the tank
- *NOTE: Take into account the volume of water in the distribution loop, this will provide the system with the appropriate amount of cleaner for the Bicarb unit.*
- Let the solution mix for approximately one minute, and then turn the **MIXER CONTROL Switch** to **OFF**.

CLEAN BICARB UNIT and LOOP PROCEDURE

8. Open the following valves:

- Open **Loop Return to Drain Valve (B8)**
- Open **Tank#1 Pump Service Valve (B11)**
- Open **Tank#2 Pump Service Valve (B12)**

9. Start the pump to circulate the solution through the loop and to drain:

- Turn the **OPERATE-OFF Switch** to **OPERATE**
- Press the **PUMP START Button**. After the air-purge cycle completes, the pump will start.



10. Using a pH Test Kit, test the dilution strength of the solution at the **Loop Return Sample Port (B17)** and compare it to the initial baseline pH reading. *Allow some time for the solution to flow since the time it will take before a change may be seen is also based on the length of the distribution loop, and the time it will take for the solution to flow from the tanks through the loop and back.*

- If the pH readings are not distinctly different, then add additional cleaner to each tank, and recheck until a distinct pH reading is achieved.

11. Let the solution go to drain until the Tanks have approximately 15 gallons each, then allow to circulate...

- Open **Tank#1 Loop Return Valve (B6)**
- Open **Tank#2 Loop Return Valve (B7)**
- Close **Loop Return to Drain Valve (B8)**

12. Using a pH Test Kit, test the dilution strength of the solution at the **Loop Return Sample Port (B17)** and compare it to the initial baseline pH reading. *Allow some time for the solution to flow since the time it will take before a change may be seen is also based on the length of the distribution loop, and the time it will take for the solution to flow from the tanks through the loop and back.*

- If the pH readings are not distinctly different, then add additional cleaner to each tank, and recheck until a distinct pH reading is achieved.

13. During circulation, disinfect Jug Fill Hose...

- Obtain a container to collect solution from the Hose.
- Attach the Jug Fill Hose to **Tank#1 Jug Fill Quick-Disconnect Fitting** then slowly open the valve on the end of the Jug Fill Hose for approximately 10 seconds to let the solution flow through

the hose, then close it.

14. Clean the Sample Ports...

- Obtain the same container used above to clean the hoses.
- While holding the container under the port, slowly open **Tank#1 Sample Port (B18)** and allow solution to flow through the port into the container for a few seconds then close **Tank#1 Sample Port (B18)**.
- While holding the container under the port, slowly open **Tank#2 Sample Port (B19)** and allow solution to flow through the port into the container for a few seconds then close **Tank#2 Sample Port (B19)**.
- Safely discard the solution in the container.
- Also Open **Loop Return Sample Port (B17)** for a several seconds to allow solution to flow through it, and then close **Loop Return Sample Port (B17)**.

15. Clean points of use along distribution loop...

- Obtain the same container used above to clean the sample ports.
- Open each of the points of use and allow solution to flow through for several seconds, into the container, until the solution tests positive for cleaner.
- Safely discard the solution in the container.

16. The solution should circulate in Tanks and Loop for a minimum of 30 minutes up to 60 minutes. This is the total circulation time which started at step 11.

17. Turn **DISINFECT Key Switch** to **OFF**.

- Remove the **Disinfect Key** from the switch and secure it away from the Bicarb unit.

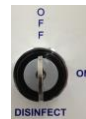

18. Do the following to clean the fill lines:

- Open **Disinfect Valve (B21)**
- Open **Tank#1 Fill Valve (B4)**
- Open **Tank#2 Fill Valve (B5)**
- Close **Tank#1 Loop Return Valve (B6)**
- Close **Tank#2 Loop Return Valve (B7)**
- Allow solution to circulate for 5 minutes.

19. Turn the pump off:

- Turn **OPERATE-OFF Switch** to **OFF**



20. Drain solution from the tanks and loop:

- Open the **Loop Return to Drain Valve (B8)**
- Open **Tank#1 Drain Valve (B13)**
- Open **Tank#2 Drain Valve (B14)**
- Close **Disinfect Valve (B21)**
- Close **Tank#1 Fill Valve (B4)**
- Close **Tank#2 Fill Valve (B5)**
- Let solution run to drain until the tanks are empty.

RINSE PROCEDURE

21. Rinse down the entire inside of each tank by doing the following:

- Turn **TANK FILL SWITCH** to **#1** and open **Tank#1 Fill Valve (B4)**
- Allow Tank#1 to rinse, then close **Tank#1 Fill Valve (B4)**
- Turn **TANK FILL SWITCH** to **#2** and open **Tank#2 Fill Valve (B5)**
- Allow Tank#1 to rinse, then close **Tank#2 Fill Valve (B5)**
- When finished turn **TANK FILL SWITCH** to the **OFF** position.



22. Once the tanks are both empty, close **ALL VALVES**.

23. Fill both tanks with 30 gallons of water:

* *NOTE: Facilities with a large number of stations may require more water to complete the rinse, so adjust accordingly.*

- Open the **Tank#1 Fill Valve (B4)** and turn **TANK FILL Switch** to **#1**
- When properly filled, close **Tank#1 Fill Valve (B4)**
- Open the **Tank#2 Fill Valve (B5)** and turn **TANK FILL Switch** to **#2**
- When properly filled, close **Tank#2 Fill Valve (B5)** and turn **TANK FILL Switch** to **OFF**

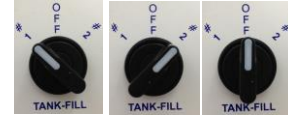

24. Open the following valves:

- Open **Tank#1 Pump Service Valve (B11)**
- Open **Tank#2 Pump Service Valve (B12)**
- Open the **Loop Return to Drain Valve (B8)**

25. Start the pump to run the rinse water to drain:

- Turn **OPERATE-OFF Switch** to **OPERATE**
- Press the **PUMP START Button**. After the air-purge cycle completes, the pump will start.

* *Be careful not to let the pump run dry. If during the next several steps, turn the pump off when the water level in either tank drops to 10 gallons. If the rinse is not complete simply return to step 22 and fill with more water to allow for a proper rinse.*



26. While rinse water is draining, rinse Jug Fill Hose...

- Obtain a container to collect solution from the Hose.
- Slowly open the valve on the end of the Jug Fill Hose for approximately 30 seconds to let rinse water flow through the hose, then close it.
- Disconnect and store the Jug Fill Hose.

27. While rinse water is draining, rinse Sample Ports...

- Obtain the same container used above to rinse the hoses.
- While holding the container under the port, slowly open **Tank#1 Sample Port (B18)** and allow rinse water to flow through the port into the container for approximately 30 seconds then close **Tank#1 Sample Port (B18)**.
- While holding the container under the port, slowly open **Tank#2 Sample Port (B19)** and allow rinse water to flow through the port into the container for approximately 30 seconds then close **Tank#2 Sample Port (B19)**.
- Safely discard the solution in the container.
- Also Open **Loop Return Sample Port (B17)** for approximately 30 seconds to allow rinse water to flow through it, and then close **Loop Return Sample Port (B17)**.

28. While rinse water is draining, rinse points of use along distribution loop...

- Obtain the same container used above to rinse the sample ports.
- Open each of the points of use and allow rinse water to flow through for several seconds, into the container, until the solution tests negative for cleaner.
- Safely discard the solution in the container.

29. Using a pH Test Kit, test the water at any of the use points throughout the Bicarb unit and distribution system and compare them to the initial baseline pH reading. Allow water to flow from ports for at least 10 seconds before sampling.

- If the pH readings are not equal to the initial baseline pH reading then repeat steps 22 through 28 until they are equal.

30. Do the following to allow the header to rinse.

- Open **Tank#1 Fill Valve (B4)**
- Open **Tank#2 Fill Valve (B5)**
- Open **Disinfect Valve (B21)**
- Close **Loop Return to Drain Valve (B8)**
- Allow to rinse for a minimum of 5 minutes

31. Using a pH Test Kit, test the water coming from the **RO Fill Inlets**, and compare them to the initial baseline pH reading. Allow water to flow from ports for at least 10 seconds before sampling.

- If the pH readings are not equal to the initial baseline pH reading then repeat step 30 until they are equal.

32. Turn the pump off when either the above steps are complete or the water level in either tank reaches 10 gallons. If the rinse is not complete and either tanks' water levels reach 10 gallons, simply add a sufficient amount of water to each tank to complete the rinse steps above.

- Turn **OPERATE-OFF Switch** to **OFF**.



33. Open the following valves and let the tanks drain until empty:

- Open **Tank#1 Drain Valve (B13)**
- Open **Tank#2 Drain Valve (B14)**

34. Once the tanks are empty, close **ALL VALVES**.

35. Do the following to rinse the loop return hose for Tank#2...

- Open **Tank#2 Drain Valve (B14)**
- Open **Tank#1 Fill Valve (B4)** and turn **TANK FILL Switch** to **#1** to fill Tank#1 with approximately 30 gallons of water.
- When properly filled close **Tank#1 Fill Valve (B4)** and turn **TANK FILL Switch** to **OFF**.
- Open **Tank#2 Loop Return Valve (B7)**
- Open **Tank#1 Pump Service Valve (B11)**



36. Start the pump to return water to Tank#2 and on to drain:

- Turn **OPERATE-OFF Switch** to **OPERATE**.
- Press the **PUMP START Button**. After the air-purge cycle completes, the pump will start.
- To prevent the pump from running dry, when only 10 gallons of water remain in Tank#1, turn the pump off by turning the **OPERATE-OFF Switch** to **OFF**.

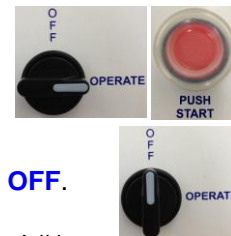

37. Once Tank#2 is empty do the following to rinse the loop return hose for Tank#1...

- Open **Tank#1 Loop Return Valve (B6)**
- Open **Tank#2 Pump Service Valve (B12)**
- Open **Tank#1 Drain Valve (B13)**
- Close **Tank#2 Loop Return Valve (B7)**
- Close **Tank#1 Service Valve (B11)**
- Close **Tank#2 Drain Valve (B14)**
- Open **Tank#2 Fill Valve (B5)** and turn **TANK FILL Switch** to **#2** and fill Tank#2 with approximately 30 gallons of water
- When properly filled close **Tank#2 Fill Valve (B5)** and turn **TANK FILL Switch** to **OFF**.



38. Start the pump:

- Turn **OPERATE-OFF Switch** to **OPERATE**.
- Press the **PUMP START Button**. After the air-purge cycle completes,



the pump will start.

- To prevent the pump from running dry, when only 10 gallons of water remain in Tank#2, turn the pump off by turning the **OPERATE-OFF Switch** to **OFF**
- Open **Tank#2 Drain Valve (B14)** to drain Tank#2 until empty.



39. Close **ALL VALVES**.

FINAL RINSE PROCEDURE

40. Fill each Tank with the approximately 20 gallons of water.

- Open the **Tank#1 Fill Valve (B4)**
- Turn **TANK FILL Switch** to **#1**
- When properly filled, close **Tank#1 Fill Valve (B4)**
- Open **Tank#2 Fill Valve (B5)** and turn **TANK FILL Switch** to **#2**
- When properly filled, close **Tank#2 Fill Valve (B5)** and turn **TANK FILL Switch** to **OFF**



41. Open the following valves:

- Open **Tank#1 Loop Return Valve (B6)**
- Open **Tank#2 Loop Return Valve (B7)**
- Open **Tank#1 Pump Service Valve (B11)**
- Open **Tank#2 Pump Service Valve (B12)**

42. Start the pump:

- Turn **OPERATE-OFF Switch** to **OPERATE**.
- Press the **PUMP START Button**. After the air-purge cycle completes, the pump will start.



** Be careful not to let the pump run dry. If during the next step, turn the pump off if the water level in either tank drops to 10 gallons. If the rinse is not complete simply return to step 40 and fill with more water to allow a proper rinse.*

43. Using a pH Test Kit, test the water from **Loop Return Sample Port (B17)**, **Tank#1 Sample Port (B18)**, **Tank#2 Sample Port (B19)** and compare them to the initial baseline pH reading. Allow water to flow from ports for at least 10 seconds before sampling.

- If the pH readings are not equal to the initial baseline pH reading then repeat steps 39 through 42 until they are equal.

44. Do the following to allow the tanks to drain until empty:

- Open **Loop Return to Drain Valve (B8)**
- Open **Tank#1 Drain Valve (B13)**
- Open **Tank#2 Drain Valve (B14)**
- Close **Tank#1 Loop Return Valve (B6)**
- Close **Tank#2 Loop Return Valve (B7)**

45. Close **ALL VALVES** and turn all **SWITCHES** to **OFF**.

46. Verify that the **DISINFECT Switch** is in the **OFF** position, and that the **Disinfect Key** has been removed from the switch and secured away from the Bicarb unit.

SYSTEM MAINTENANCE, General

Maintenance Task	Frequency (more often if needed)	Notes
Check the system for leaks	Daily	Visual Inspection
Monitor the system for unusual sounds	Daily	Auditory Inspection
Clean external surfaces	Weekly	Use a soft, damp towel or sponge. (DO NOT USE BLEACH)
Disinfect	Weekly Not on the same day as the cleaning	See Disinfecting Procedure section
Clean	Monthly Not on the same day as the disinfection	See Cleaning Procedure section
Calibrate the Bicarb Unit Regulator	Every 3 months	See the System Maintenance – Calibrate the Bicarb Regulator for Floor-Valve-Boxes and Panels section

SYSTEM MAINTENANCE, Calibrating the Bicarb Unit Regulator for Floor-Valve-Boxes and Panels

It is recommended that regulators should be calibrated every 3 months by qualified technicians. This be performed using the Concentrate Regulator Calibration Kit which is available from Better Water LLC.

The stated pressures are typical but can vary based on the specific dialysis machines in use.

- Pull the Regulator Handle out, and turn it counter-clockwise until it stops.
 - This will set the static pressure to 0 psi.
- Plug in the Blue-Bicarb Wand from the Calibration Kit.
* *NOTE: the Red-Wand is for calibrating acid regulators.*
- Close the Valve on the Calibration Kit.
- Open the Bicarb Valve on the Wall Box/Panel.
- Turn the Regulator Handle clockwise until the static pressure reading on the Calibration Kit Gauge starts to increase and reads between 1.0 and 1.5 psi.
 - Adjust by turning the Regulator Handle until the static pressure is between 1.0 and 1.5 psi.
 - Turn counter-clockwise to decrease the static pressure
 - Turn clockwise to increase the static pressure

- *NOTE: Pressure should NOT be set to over 2 psi static pressure.*



part#
EQASSYCC01
Concentrate Regulator
Calibration Kit

- 6.** Pressure on the Calibration Kit Gauge should read between 1 and 1.5 psi, with no water flowing through the Calibration Kit.
 - a.** If the psi reading is not between 1.0 and 1.5 psi repeat step 5.
- 7.** With the static pressure set between 1.0 and 1.5 psi, slowly open the Valve on the Calibration Kit and allow the flow to run to drain to check flow.
- 8.** After setting the static psi and checking the flow, close the Bicarb Valve on the Wall Box/Panel.
- 9.** Disconnect the Calibration Kit.
- 10.** Allow any remaining liquid to run drain until it stops draining.
- 11.** Push the Regulator Handle back into the Regulator to lock the Handle into place.

LONG TERM STORAGE









PUTTING BICARB UNIT INTO STORAGE

1. Drain all solution from the Unit.
2. Clean and disinfect the Unit.
3. Disconnect power and wrap power cord.
4. Disconnect from water source.
5. Disconnect Loop Feed and Loop Return.
6. Open all valves on the Header and Tank to allow complete draining and drying.
7. Allow unit to completely air dry.
- NOTE: Under no circumstances should the unit be stored in a "wet" condition (any liquids). Storing "wet" can cause damage to the components, and contamination of the Bicarb unit.
8. Disconnect from Drain.
9. Store with the Lid closed to prevent foreign objects from entering the Tank.
10. Zip-tie plastic bags over all openings to prevent contamination.

BRINGING BICARB UNIT BACK FROM STORAGE









1. Remove protective plastic bags from openings.
2. Reconnect to Drain.
3. Reconnect Loop Feed and Loop Return.
4. Reconnect to water source.
5. Open and/or close the necessary valves on the Loop and Header before use.
6. Reconnect to power.
7. Clean and disinfect the Unit and Loop.

RELATED REPLACEMENT PARTS

DESCRIPTION	PART#	PICTURE
Propeller Shaft - 316 Stainless Steel	EQBICB00471	
Propeller - Polypropylene	EQBICB01923	
Propeller Set Screw - Stainless Steel; one per propeller	EQBICB01920	
Shaft Coupling - Stainless Steel	EQBICB00472	
Coupling Set Screw - Stainless Steel; four per coupling	HWSCSS01920	
Mixer Motor - 1/4 HP, 115 VAC	EQBICB01868	
Mixer-Motor Power Cord - for Mix/Delivery Bicarb units	ELPCOO00200	
MD 100RLT Pump - 1/3 HP, 1 Phase, 115 VAC	EQPUIW00453	



Pictures do not reflect the size of the item in relation to the other pictures

RELATED REPLACEMENT PARTS

DESCRIPTION	PART#	PICTURE
1000 FT Loop Pump - 3/4 HP, 1 Phase, 115 VAC	EQPUGR00600	
High Level Proximity Sensor Subassembly, Tank 1	EQSUBTNK1HL	
Low Level Proximity Sensor Subassembly, Tank 1	EQSUBTNK1LL	
High Level Proximity Sensor Subassembly, Tank 2	EQSUBTNK2HL	
Low Level Proximity Sensor Subassembly, Tank 2	EQSUBTNK2LL	
Flow Control, 2.0 GPM PVC Sch-80	PLFCS802001	
Check Valve, 1/2", 316 Stainless-Steel	PLVASS00846	
Flow-Switch, 3/4", PVC-Clear	PLFSS800444	





Pictures do not reflect the size of the item in relation to the other pictures

RELATED REPLACEMENT PARTS

DESCRIPTION	PART#	PICTURE
Volara Foam for Tank Lid, .25" TK x 1.5" W * 6 ft for 60 gallon Tanks * 10 ft for 100 gallon Tanks	EQBICB01600	
1/2" Red Handle Valve, Asahi * Valve B21	PLVAS800167-A	
1/2" Blue Handle Valve, Asahi * Valves B6, B7	PLVAS800198-A	
3/4" Red Handle Valve, Asahi * Valve B8	PLVAS800169-A	
3/4" Blue Handle Valve, Asahi * Valves B11, B12	PLVAS800170-A	
1" Red Handle Valve, Asahi * Valves B13, B14	PLVAS800174-A	
1/2" Red Handle, Compact Valve * Valves B4, B5	PLVAS8C0004	
1/4" Plastic Solenoid Valve * Air-purge valve	PLVA021	

Pictures do not reflect the size of the item in relation to the other pictures

RELATED REPLACEMENT PARTS

DESCRIPTION	PART#	PICTURE
Bicarb Unit Control Box	EQASSYBCB01854	
Fuse, 3 Amp, Little-Fuse <i>* For models manufactured before mid-September 2013</i>	ELLFFS00834	
Fuse, 2 Amp, Little-Fuse <i>* For models manufactured after mid-September 2013</i>	ELLFFS00832	
Bicarb Remote Alarm Box	EQASSYBCB01709	
Concentrate Regulator Calibration Kit <i>* For calibrating regulators in Floor-Valve-Boxes and Panels</i> <i>* Blue wand is for bicarbonate; Red wand is for acid</i>	EQASSYCC01	

Pictures do not reflect the size of the item in relation to the other pictures

TROUBLE-SHOOTING GUIDE

The information in this document is intended to serve as a guide only for qualified operators. It is not all inclusive of the problems that may be encountered. This guide should aid operators with reminders and routine trouble-shooting tasks.

For any problem outside the confines of this guide, call for technical assistance.

Problem	Possible Causes	Possible Solutions
Mixer will not operate	<ol style="list-style-type: none"> 1. Bicarb unit not plugged into electrical receptacle 2. Tripped breaker 	<ol style="list-style-type: none"> 1. Verify that the Bicarb unit is plugged into an electrical receptacle. 2. Reset breaker if necessary.
“”	<ol style="list-style-type: none"> 3. MIXER CONTROL Switch is OFF 	<ol style="list-style-type: none"> 1. Turn MIXER CONTROL Switch from OFF to either #1 or #2.
“”	<ol style="list-style-type: none"> 4. Blown fuse in the Control Box 	<ol style="list-style-type: none"> 1. Check fuses in Control Box and replace if necessary.
“”	<ol style="list-style-type: none"> 5. Relays in Control Box not making a good connection 	<ol style="list-style-type: none"> 1. Check that the relays in the Control Box are making a good connection by turning them fully OFF and ON.
Low-Level Alarm not working	<ol style="list-style-type: none"> 1. TANK ALARM Switch is OFF 	<ol style="list-style-type: none"> 1. Turn TANK ALARM Switch from OFF to either #1 or #2.
“”	<ol style="list-style-type: none"> 2. Level in the Tank is above the level of the proximity sensor 	<ol style="list-style-type: none"> 1. Nothing is wrong if the level is above the proximity sensor.
“”	<ol style="list-style-type: none"> 3. Blown fuse in the Control Box 	<ol style="list-style-type: none"> 1. Check fuses in Control Box and replace if necessary.
“”	<ol style="list-style-type: none"> 5. Loose switch connection 	<ol style="list-style-type: none"> 1. Check all switch wire connections. 2. Disconnect and reconnect to verify connection.
Tank will not hold water or bicarbonate solution	<ol style="list-style-type: none"> 1. Drain is open 	<ol style="list-style-type: none"> 1. Verify Drain Valve is closed.
Green PUMP INDICATOR Light won't illuminate	<ol style="list-style-type: none"> 1. Pump may not be running 	<ol style="list-style-type: none"> 1. Check to see if the distribution pump is actually running. This can be done by looking at the end of the pump to see if the fan is turning.
“”	<ol style="list-style-type: none"> 2. Burned out bulb 	<ol style="list-style-type: none"> 1. Replace the bulb.
Distribution pump won't run	<ol style="list-style-type: none"> 1. OPERATE-OFF Switch is OFF 	<ol style="list-style-type: none"> 1. Turn OPERATE-OFF Switch from OFF to OPERATE. 2. Press the PUMP START Button to restart the pump.
“”	<ol style="list-style-type: none"> 2. The Tank is empty 	<ol style="list-style-type: none"> 1. The Pump will not run if the Tank is empty. Fill accordingly before retrying

Problem	Possible Causes	Possible Solutions
Distribution pump won't run	3. Valves not in the correct position	<ol style="list-style-type: none"> 1. Verify the Loop Service Valve and/or the Pump Service Valves are open. 2. Verify either the Bicarb Return Valve or the Drain Valve are open.
“”	4. Blown fuse in the Control Box	<ol style="list-style-type: none"> 1. Check fuses in Control Box and replace if necessary.
“”	5. Bicarb unit not plugged into electrical receptacle 6. Tripped breaker	<ol style="list-style-type: none"> 1. Verify that the Bicarb unit is plugged into an electrical receptacle. 2. Reset breaker if necessary.
“”	7. Pump or Flow Switch wiring has come unplugged	<ol style="list-style-type: none"> 1. Verify that the Pump wiring is plugged in. 2. Verify that the Flow Switch wiring is plugged in.
“”	8. Flow switch not working	<ol style="list-style-type: none"> 1. Check the Flow Switch and replace if necessary.

LIMITED WARRANTY TERMS and CONDITIONS

- a. This limited warranty is given only to the original buyer and covers the equipment delivered with this limited warranty.
- b. The buyer shall be barred from any recovery on this limited warranty or otherwise for damages due in whole or in part to...
 - ... unreasonable use
 - ... improper operation
 - ... use beyond normal fashion
 - ... failure to follow instructions
 - ... failure to maintain the product in good condition and repair
 - ... or the like.
- c. If the buyer discovers or should have discovered a defect in which it is reasonable to conclude that damage, either personal, property, or economic, may result, the buyer's continued use of the product shall constitute any assumption of risk by the buyer and a bar to any recovery for breach of this limited warranty or otherwise.
- d. No oral or written representation, information, or advice given by Better Water LLC or any of its representatives shall create a warranty or in any way increase the scope of this express limited warranty and shall not form a part of the basis for bargain.

WHAT IS WARRANTED AND FOR HOW LONG?

- a. All equipment, excluding ion exchange and filtration media and cartridges, are warranted to be free from factory defects in materials, and workmanship under normal use for a period of one (1) year from the date of shipment.
- b. It is a condition precedent to recovery on this limited warranty that the buyer strictly comply with all operating and maintenance guidelines established by Better Water LLC and that the serial number (*if applicable*) is intact and legible on the equipment.
- c. It is a condition precedent to recovery on this limited warranty for damage to the external finish of the equipment that the buyer notifies Better Water LLC at the time of the installation that the finish is damaged.

WHAT IS REMEDY FOR BREACH OF THIS LIMITED WARRANTY or NEGLIGENCE BY BETTER WATER LLC

- a. Buyer's sole and exclusive remedy for any breach of this limited warranty or negligence by Better Water LLC shall be repair or replacement of the defective part, at the option of Better Water LLC, provided such defective part is returned to Better Water LLC for inspection.
- b. Better Water LLC shall not be obligated to supply an exact replacement of the defective part and reserves the right to substitute new and improved parts.
- c. Better Water LLC shall provide at no cost to buyer, labor to remove and/or replace defective parts covered by this limited warranty for a period of ninety (90) days from the date of installation by Better Water LLC of the equipment.
- d. After such ninety (90) day period, buyer shall be responsible for any labor or service charge for the removal and/or replacement of any defective parts.
- e. Buyer shall be responsible for all travel expenses and freight charges at all times.
- f. Better Water LLC shall have no obligation to repair or replace any defective part if buyer fails to follow the procedure set forth in "HOW TO OBTAIN A REPLACEMENT PART UNDER LIMITED WARRANTY".

IN NO EVENT SHALL THIS LIMITED WARRANTY BE CONSTRUED TO COVER, NOR SHALL BETTER WATER LLC BE LIABLE TO BUYER AS ANY OTHER PERSON FOR, ANY CONSEQUENTIAL, INCIDENTAL, ECONOMIC, DIRECT, INDIRECT, GENERAL OR SPECIAL DAMAGES, WHICH ARE HEREBY EXPRESSLY DISCLAIMED.

HOW TO OBTAIN A REPLACEMENT PART UNDER LIMITED WARRANTY

- a. Buyer should contact the Customer Service or Technical Support Departments and request a Return Goods Authorization.
- b. Described part(s) will be sent with a purchase order.
- c. The returned part(s) will be returned to the factory for limited warranty consideration. If part(s) are not covered under the limited warranty, part(s) will be considered billable against the purchase order supplied.

WHAT IS NOT COVERED BY THIS LIMITED WARRANTY:

By way of example and not limitation, this limited warranty does not cover:

- Damage to or replacement of any ion exchange resin or filter media
- Labor or service charges for the removal and/or replacement of any defective parts after the ninety (90) day period from the date of installation or sale by Better Water LLC
- Freight charges and travel expenses
- Damage from inadequate or defective wiring, improper voltage, improper connections or electrical service, inadequate or defective plumbing, water supply, or water pressure, or in violation of applicable building, plumbing or electrical codes, laws, ordinances or regulations.
- Damage from improper installation or operation, including but not limited to, abuse, accident, neglect, improper maintenance, freezing and fires, or abnormal use.
- Damage caused by contaminants in Buyer's water supply, including hardness, chlorine, chloramines, sulfur, bacterial iron, tannin, algae, oil, organic matter or other unusual substances, if special equipment has not been installed by Better Water LLC to remove such contaminants
- Damage to or caused by filters/membranes or other replacement parts not purchased from Better Water LLC or damage caused by modification, alteration, repair or service of the equipment or any of its parts by anyone other than Better Water LLC or its expressly authorized representatives.

APPENDIX A

CALCULATIONS & CONVERSIONS

BLEACH DISINFECTING DILUTIONS

- a. 5.25% household bleach is 52,500 ppm Sodium Hypochlorite
- b. 6.25% household bleach is 62,500 ppm Sodium Hypochlorite
- c. 8.25% household bleach is 82,500 ppm Sodium Hypochlorite

1:50 Dilution

5.25% = 1050 ppm
6.25% = 1250 ppm
8.25% = 1650 ppm

Tank Gallons x 2.56 = ounces of bleach 5.25%
Tank Gallons x 1.92 = ounces of bleach 6.25%
Tank Gallons x 1.46 = ounces of bleach 8.25%

1:100 Dilution

5.25% = 525 ppm
6.25% = 625 ppm
8.25% = 825 ppm

Tank Gallons x 1.28 = ounces of bleach 5.25%
Tank Gallons x 0.96 = ounces of bleach 6.25%
Tank Gallons x 0.73 = ounces of bleach 8.25%

1:500 Dilution

5.25% = 105 ppm
6.25% = 125 ppm
8.25% = 165 ppm

Tank Gallons x 0.256 = ounces of bleach 5.25%
Tank Gallons x 0.192 = ounces of bleach 6.25%
Tank Gallons x 0.146 = ounces of bleach 8.25%

1:1000 Dilution

5.25% = 52.5 ppm
6.25% = 62.5 ppm
8.25% = 82.5 ppm

Tank Gallons x 0.128 = ounces of bleach 5.25%
Tank Gallons x 0.096 = ounces of bleach 6.25%
Tank Gallons x 0.074 = ounces of bleach 8.25%

CONVERSION FORMULAS

OUNCES to MILLILITERS

Formula: **Fluid Ounces x 29.6 = Milliliters**

Example: 128 oz x 29.6 = 3790 milliliters

MILLILITERS to OUNCES

Formula: **Milliliters / 29.6 = Ounces**

Example: 750 ml / 29.6 = 25.34 ounces

GALLONS to OUNCES

Formula: **Gallon * 128 = Ounces**

*Example: 1 gal * 128 = 128 ounces*

OUNCES to GALLONS

Formula: **Ounces / 128 = Gallons**

Example: 128 ounces / 128 = 1 Gallon

CALCULATION for AREA of PIPE VOLUME

To calculate the cross sectional area of pipe, use the following formula: $\text{Area} = \pi \times r^2$

- $\pi = 3.14$

- r = radius (*which is 1/2 the diameter*)

The following calculation uses a 1" diameter pipe as an example:

Calculate the cross sectional area of the pipe using the formula above:

- | | |
|---|---|
| 1. Divide the diameter by 2 to get the radius in inches | $1" \text{ diameter} / 2 = \mathbf{0.5 \text{ inches}}$ |
| 2. Divide the radius by 12 to convert from inches to feet | $0.5 / 12 = \mathbf{0.0417 \text{ feet}}$ |
| 3. Square the radius | $0.0417^2 = \mathbf{.00174 \text{ sq ft}}$ |
| 4. Multiply by pi | $0.00174 \times 3.14 = \mathbf{.00546 \text{ sq ft}}$ |

Answer: the area of a 1" diameter pipe is 0.00546 ft²

3 FEET per SECOND FLOW VELOCITY RATES**Nominal Loop Pipe Inner Diameter**

3/4" Teflon id	=	0.60in.
3/4" schedule 80 pvc id	=	0.74in
1" Teflon id	=	0.88in
1" schedule 80 id	=	0.96in
1 1/2" schedule 80 id	=	1.48 in
3/4" (25mm) polypropylene id	=	0.80in
1" (32mm) polypropylene id	=	1.03in
1 1/2" (50mm) polypropylene id	=	1.61 in

Nominal Flow Rates at 3 Feet per Second

3/4" Teflon	=	2.64 gpm @ 3ft/sec (Nominal)
3/4" schedule 80 pvc	=	4.02 gpm @ 3ft/sec (Nominal)
1" Teflon	=	5.69 gpm @ 3ft/sec (Nominal)
1" schedule 80	=	6.77 gpm @ 3ft/sec (Nominal)
1 1/2" schedule 80	=	16.1 gpm @ 3ft/sec (Nominal)
3/4" (25mm) polypropylene	=	4.70 gpm @ 3ft/sec (Nominal)
1" (32mm) polypropylene	=	7.79 gpm @ 3ft/sec (Nominal)
1 1/2" (50mm) polypropylene	=	19.0 gpm @ 3ft/sec (Nominal)

a. All 3ft/sec flow rates at the loop return flow meter are calculated for the loop inner diameter only.

b. The above flow rates should be set with all dialysis machines running.

c. If bicarbonate or acid makeup water is required, both should have the proper flow controls to maintain flow velocity.

APPENDIX B

PRE-SHIP TEST DATA

